

Description of options

Option M2 Configurable engine control cards Multi-line 2 – version 2

4189340482B

SW version 2.4X.X

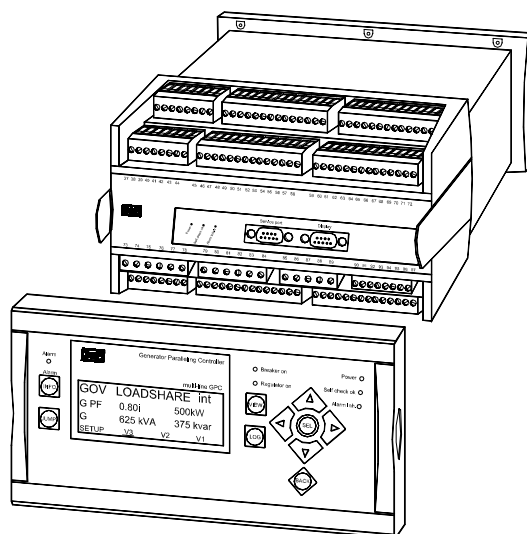

- *Description of options*
- *Functional description*
- *Display units*
- *Additional functions*
- *Parameter list*

CE

Table of contents

1. WARNINGS AND LEGAL INFORMATION	3
ELECTROSTATIC DISCHARGE AWARENESS	3
SAFETY ISSUES	3
DEFINITIONS	3
2. DESCRIPTION OF OPTION	4
OPTION M2	4
TERMINAL DESCRIPTION	5
TERMINAL STRIP OVERVIEW	6
3. FUNCTIONAL DESCRIPTION	7
ENABLE LOGIC	7
LOCAL/REMOTE SELECTION	7
START FUNCTIONS	7
STOP FUNCTIONS	8
BREAKER OPERATIONS	9
REGULATION	11
FLOWCHARTS	12
SEQUENCES	16
SYNCHRONISING	19
GENERATOR TYPE	19
4. DISPLAY UNITS	21
GPU DISPLAY	21
PPU DISPLAY	21
NOT M20	21
5. ADDITIONAL FUNCTIONS	22
INHIBIT	22
STATUS OUTPUTS	23
DIGITAL INPUT	24
INPUT ALARM FUNCTION HIGH/LOW	26
VDO INPUTS	27
RUNNING FEEDBACK	28
DELAY REGULATION	30
MODBUS/PROFIBUS/CANOPEN	31
3. PARAMETER LIST	32
DIGITAL INPUT SETUP	32
ANALOGUE INPUT SETUP	33
OVERSPEED ALARMS	34
VDO INPUT – ALARM SETUP	35
MAGNETIC PICK-UP SETUP	36
START CONTROL SETUP	36
STOP CONTROL SETUP	37
STATUS OUTPUTS	37
GENERATOR TYPE	38
VDO CHARACTERISTIC SETUP	38

This manual is valid for standard Multi-line 2 PPU/GPU/GPC units with firmware version 2.30.0 or later.

1. Warnings and legal information

DEIF takes no responsibility for installation or operation of the generator set. If there is any doubt about how to install or operate the generator set controlled by the unit, the company responsible for the installation or the operation of the set must be contacted.

The units are not to be opened by unauthorised personnel. If opened anyway, the warranty will be lost.

Electrostatic discharge awareness

Sufficient care must be taken to protect the terminals against static discharges during the installation. Once the unit is installed and connected, these precautions are no longer necessary.

Safety issues

Installing the unit implies work with dangerous currents and voltages. Therefore, the installation should only be carried out by authorised personnel who understand the risks involved in working with live electrical equipment.



Be aware of the hazardous live currents and voltages. Do not touch any AC measurement inputs as this could lead to injury or death.

Definitions

Throughout this document a number of notes and warnings will be presented. To ensure that these are noticed, they will be highlighted in order to separate them from the general text.

Notes



The notes provide general information which will be helpful for the reader to bear in mind.

Warning



The warnings indicate a potentially dangerous situation which could result in death, personal injury or damaged equipment, if certain guidelines are not followed.

2. Description of option

This document describes the functionality of engine control and protection contained in option M2.



The engine logic is referred to as option M20 on the type label. M20 can be enabled or disabled from the display.

Option M2 and M20 can be used in the following combinations:

Options	Description (function of M2)	Comments
M2 (not M20)	Input/output extension card	Requires display without start/stop functions. (Not supplied unless specified).
M2 + M20 (M20 included)	Engine logics	Requires display with start/stop functions.



Option M2 + M20 are supplied unless otherwise specified.

Option M2

Function	ANSI no.
3 x 4...20mA inputs with alarms/shutdowns	77
3 x VDO inputs (oil press., coolant temp., fuel tank level) with alarms/shutdowns	63, 26, 71, 77
Magnetic pick-up input for RPM and alarms/shutdowns	12, 14, 77
9 x binary inputs for control and/or alarms/shutdowns	77
3 x relay outputs for start/stop control	62

Terminal description

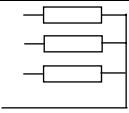
Term.	Function	Technical data	Description/preconfiguration
98	Analogue input 1 +	+4...20mA in	4...20mA input, configurable
99	Analogue input 1 -	GND	
100	Analogue input 2 +	+4...20mA in	4...20mA input, configurable
101	Analogue input 2 -	GND	
102	Analogue input 3 +	+4...20mA in	4...20mA input, configurable
103	Analogue input 3 -	GND	
104	VDO 1		Configurable (oil pressure)
105	VDO 2		Configurable (water temperature)
106	VDO 3		Configurable (fuel tank level)
107	Common		Common, term. 104-106
108	Tacho input	0.5...70V AC	RPM/magnetic pick-up/overspeed
109	Tacho input	10...10.000Hz	
110	Binary input	Optocoupler	Configurable
111	Binary input	Optocoupler	Configurable
112	Binary input	Optocoupler	Configurable
113	Binary input	Optocoupler	Configurable
114	Binary input	Optocoupler	Configurable
115	Binary input	Optocoupler	Start enable (ON = start enabled, OFF = start blocked), configurable
116	Binary input	Optocoupler	Running feedback, configurable
117	Binary input	Optocoupler	External engine failure, configurable
118	Binary input	Optocoupler	External emergency stop activated, configurable
119	Com.	Common	Common for terminals 114-118
120	NO	Relay 250V AC/8A	Crank
121	Com.		
122	NO	Relay 9 250V AC/8A	Stop coil/running coil (selectable)
123	Com.		
124	NO	Relay 250V AC/8A	Start prepare
125	Com.		

Terminal strip overview

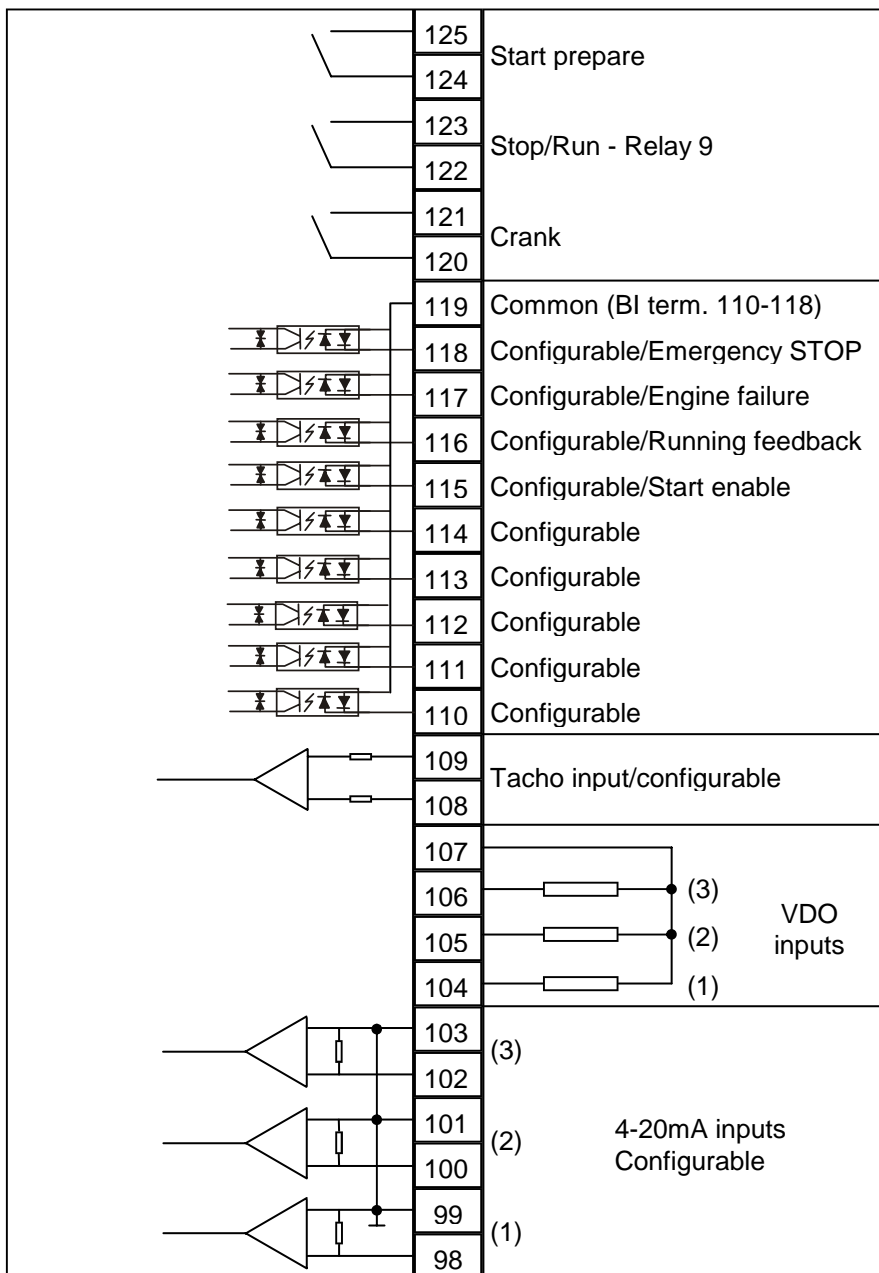

3. Functional description

Enable logic

The engine logic can be switched on or off from the display. This is done in the menu 6030. It is only possible to access the menu using the 'JUMP' push-button on the display.

To deactivate engine logics (M20 OFF), select setting '0'.



Normally, it is not necessary to touch this parameter.

You need to do this only if the option M2 PCB is to be used as an 'additional input/output PCB'. In that case a different display must be selected. Contact DEIF Support for details – preferably before ordering.

Local/remote selection

The Multi-line 2 can be used in two different operation modes: Local or remote. The modes can be selected from the display using the 'Mode' button. A LED is located next to the mode button and the LED is lit when the unit is in 'Remote'.

Communication

If the Multi-line 2 has a communication option, it is possible to change mode through the communication lines as per the table below.

	Local	Remote
Modbus	Yes	Yes
Profibus	No	No
CANopen	Yes	Yes

Start functions

The gen-set can be started from the Multi-line 2. This can be controlled while the Multi-line 2 is in local mode or remote mode.



The start sequence is described in the flowcharts.



The alarms and shutdown functions are still active regardless of the selected mode.

Local control

To start the gen-set in 'Local' mode, the Multi-line 2 is changed to local if this mode has not already been selected. This can be done by pressing the 'Mode' button on the display and the LED 'Remote' switches off.

Now, the gen-set can be started by pressing the 'Start' push-button on the display.



The regulation is not activated unless terminal 25, 'Start sync./control', is activated.

Remote control

To start the gen-set in 'Remote', the Multi-line 2 is changed to Remote if this mode has not already been selected. This can be done by pressing the 'Mode' button on the display and the LED 'Remote' switches on.

Now, the gen-set can be started by activating the digital input 'Start sync./control', terminal 25, possibly in a combination with the deload input. This depends on whether the CB must be closed or remain open.



The start button on the display cannot be used in remote mode.

Activated input	Start sync./control Terminal 25	Deload Terminal 43
Start functions		
Start gen-set	X	X
Start gen-set and close CB/synchronise	X	-



The regulation is activated when the gen-set is started and the running feedback is present.

Stop functions

The gen-set can be stopped from the Multi-line 2. This can be controlled while the Multi-line 2 is in local mode or remote mode.



The stop sequence is described in the flowcharts.

Local control

To stop the gen-set in 'Local' mode, the Multi-line 2 is changed to local if this mode has not already been selected. This can be done by pressing the 'Mode' button on the display and the LED 'Remote' switches off.

Now, the gen-set can be stopped by pressing the 'Stop' push-button. The gen-set stops immediately without cooling down.



To stop the engine, the generator breaker must be open.



If cooldown is necessary, then the only possibility is to wait the desired cooldown time until pressing the 'Stop' button.

Remote control

To stop the gen-set in 'Remote', the Multi-line 2 is changed to remote if this mode has not already been selected. This can be done by pressing the 'Mode' button on the display and the LED 'Remote' switches on.

Before the stop sequence can be initiated, the CB must be opened. To open the CB in remote, the deload input, terminal 43, must be activated at the same time as the start sync./control, terminal 25.

Now, the gen-set can be stopped by deactivating the digital input start sync./control, terminal 25.



The stop button on the display cannot be used in remote mode.

Breaker operations

In the GPC and the PPU, the circuit breaker can be operated from the Multi-line 2.



The GPU has no circuit breaker control.

The CB can be operated in two ways, push-button or digital input:

	Local	Remote
Display push-button	Yes	No
Digital input	No	Yes

The two possibilities cannot be combined, so the digital input cannot be used in local and the push-button cannot be used in remote.

Local

The gen-set is running in local mode. The regulation is either started or stopped (through activation of the terminal 25, start sync./control).

Regulation ON, close CB

When the regulation is activated, then the CB is closed by pressing the CB push-button. Now, the gen-set frequency (and voltage) is adjusted according to the settings of the synchroniser and

the GPC/PPU will issue a close CB signal accordingly.



After the CB has closed, the operation mode is determined by the mode inputs, mode 1 - mode 6.

Regulation ON, open CB

To open the CB when the GPC/PPU is in local, the CB push-button must be pressed.



In fixed power and load sharing mode the CB opens after having ramped down the load. In all other modes the breaker opens instantly.

Regulation OFF, close CB

When the regulation is deactivated, a check synchronising will take place if the CB push-button is pressed. To adjust the frequency and voltage, the manual UP/DOWN inputs (terminal 44-47) must be used. The check synchronising follows the settings of the synchroniser.



To start regulation after the CB has closed, the regulation can be activated by activating 'Start sync./control' terminal 25 and the running modes can be selected with modes 1-6.

Regulation OFF, open CB

To open the CB, press the CB push-button. Now, the CB is opened without ramping down regardless of the load.

Remote

The gen-set is running in remote mode. The regulation is either started or stopped (through activation of the terminal 25, start sync./control).

Regulation ON, close CB

When the 'Start sync./control' is ON, the synchronising is started as soon as the gen-set is started and the deload input is deactivated.



After the CB has closed, the operation depends on the mode settings.

Regulation ON, open CB

To open the CB, the terminal 43 (deload) must be activated. Now, the GPC/PPU starts the CB open sequence (ramp down/open breaker) and opens the breaker.



In fixed frequency mode, the CB trips without ramp down. In other modes, the gen-set will be deloaded before the breaker trips.

Regulation OFF, close CB

This state of operation is not possible because the stop sequence will be initiated automatically when the CB is opened and the 'Start sync./control' is OFF.

Regulation OFF, open CB

It is not possible to open the CB from the GPC/PPU when the regulation is switched off.

Regulation

The activation of the regulation follows the terminal 25, 'Start sync./control'.



For details about the 'Start sync./control' function please refer to the Designer's Reference Handbook.

In 'remote' mode, the regulation is normally activated when the gen-set is running, because the input 'Start sync./control' must be activated to start and operate the gen-set under normal conditions.

In 'local' mode, the gen-set can be started without activating the regulation (25 = OFF). In this situation, the display LED 'Regulator on' is not lit. Activate 'Start sync./control' to activate the regulation and synchronising or 'Start sync./control' + 'Deload' to just activate the regulation but without synchronising.

When the gen-set is stopped, the regulator outputs are reset to the offset position, please refer to the description of options regarding the controller outputs.

Flowcharts

Start sequence

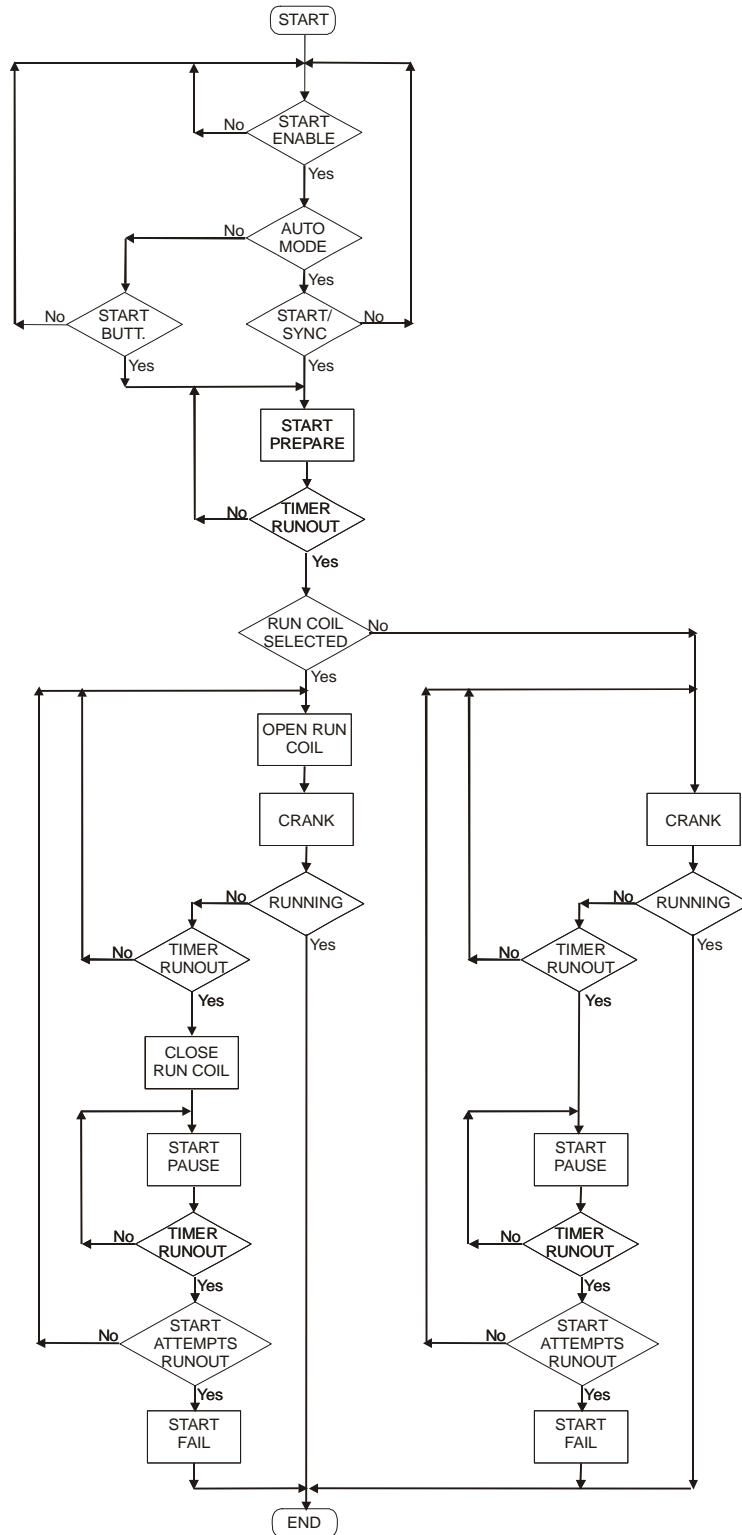

Stop sequence

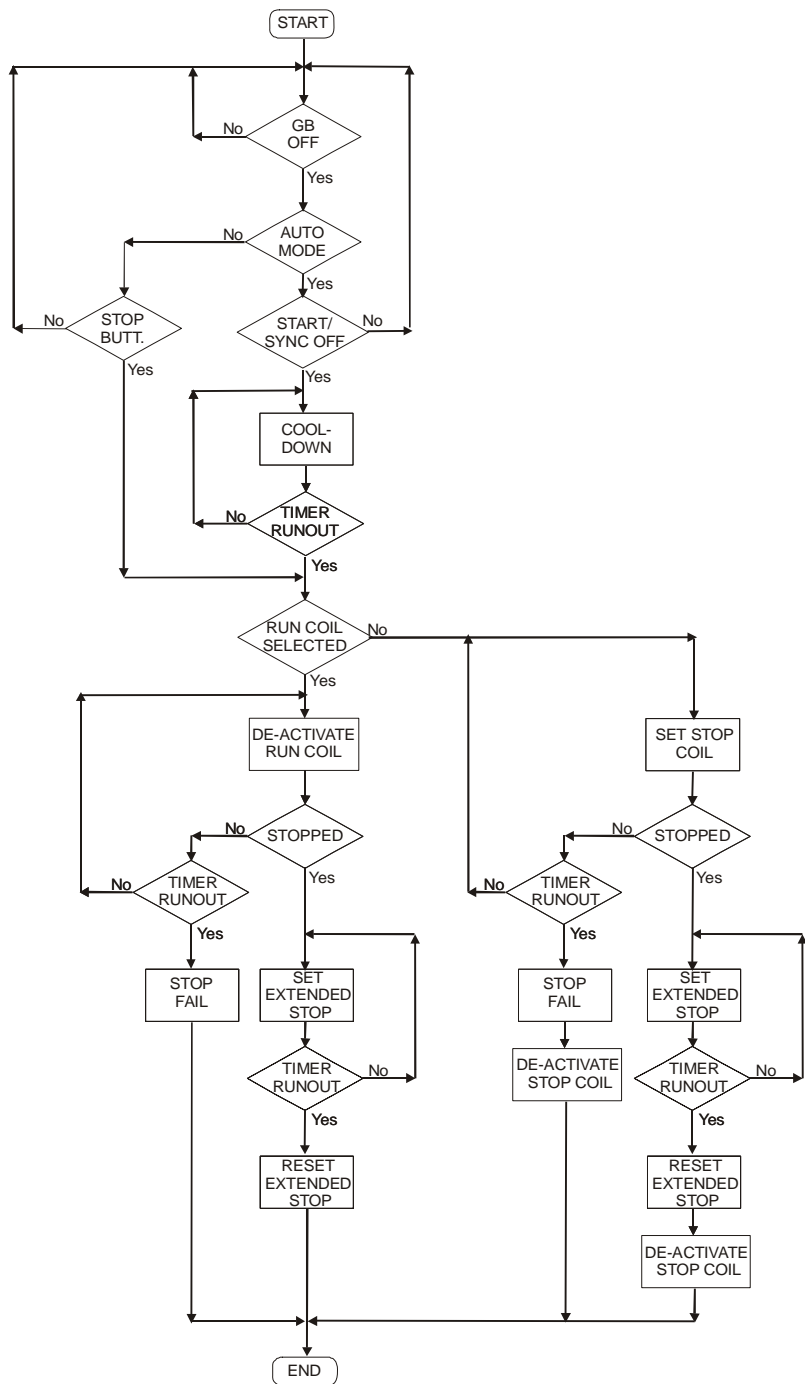

Remote sequence, flowchart A

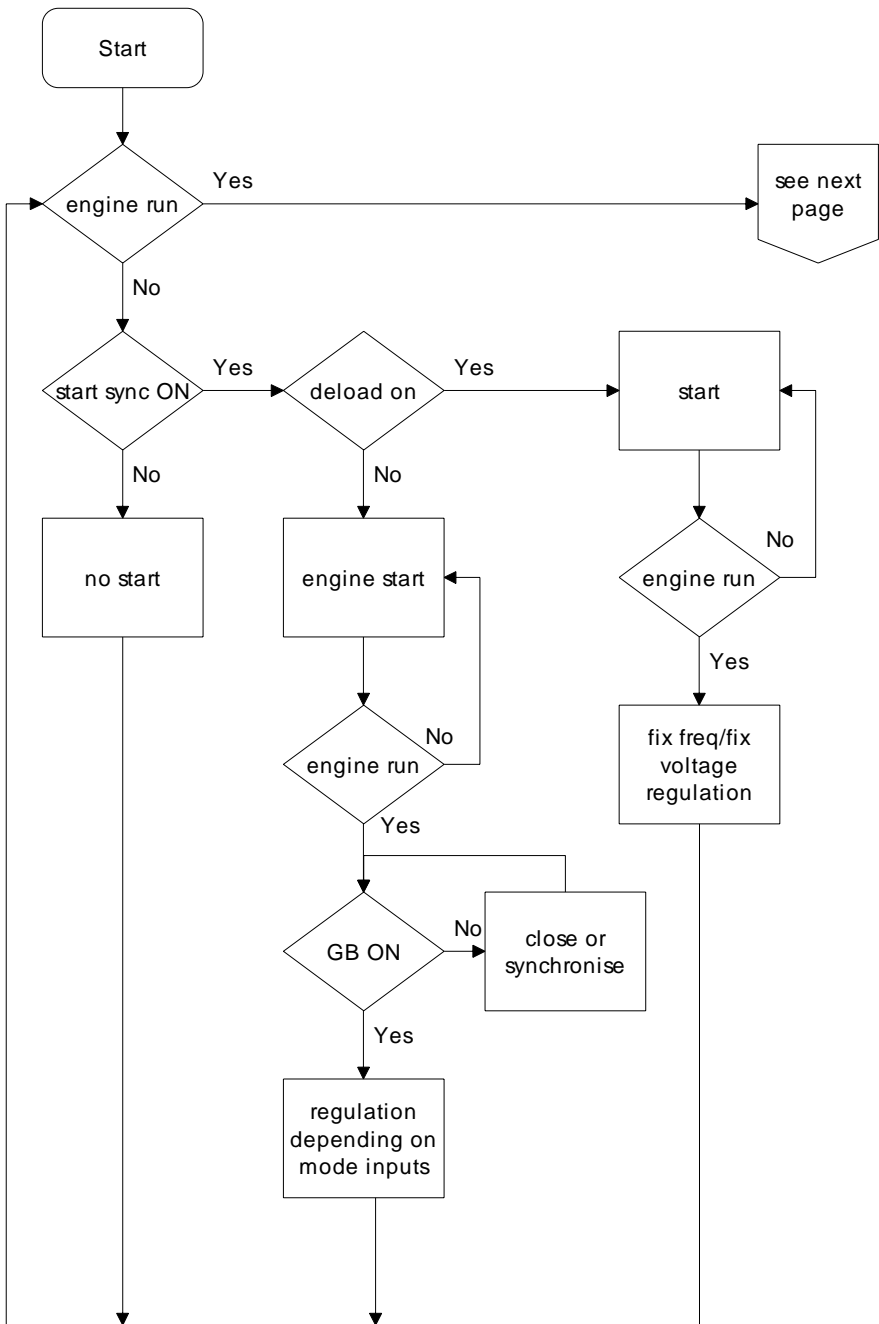

Remote sequence, flowchart B

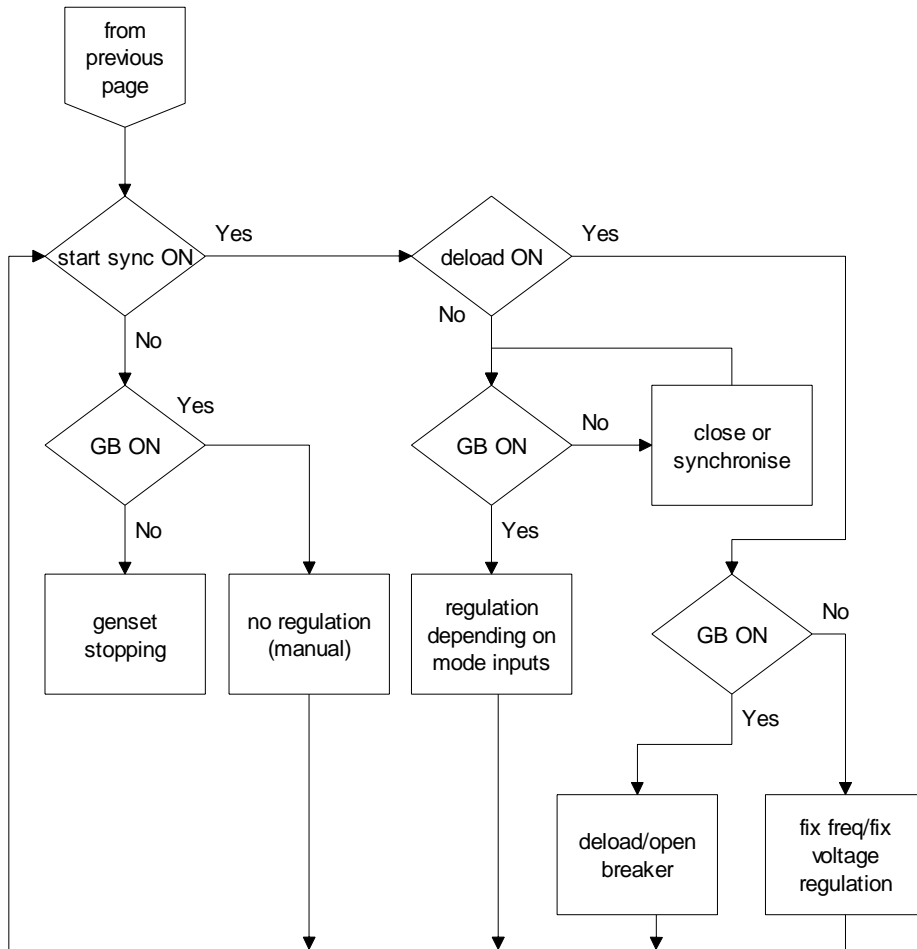

Sequences

The following contains information about the start and stop sequences of the engine. These sequences are automatically initiated if the input 'Start sync./control' is activated in remote mode, or if the start/stop push-buttons are used in local mode.

Start sequence

The drawings illustrate the start sequences of the gen-set.

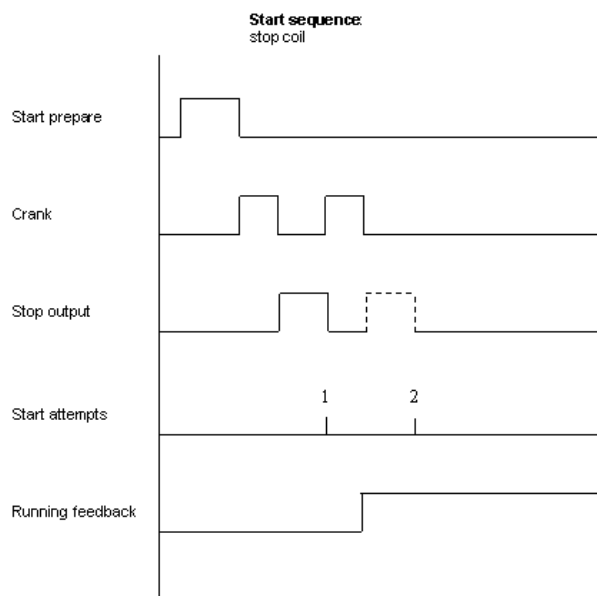
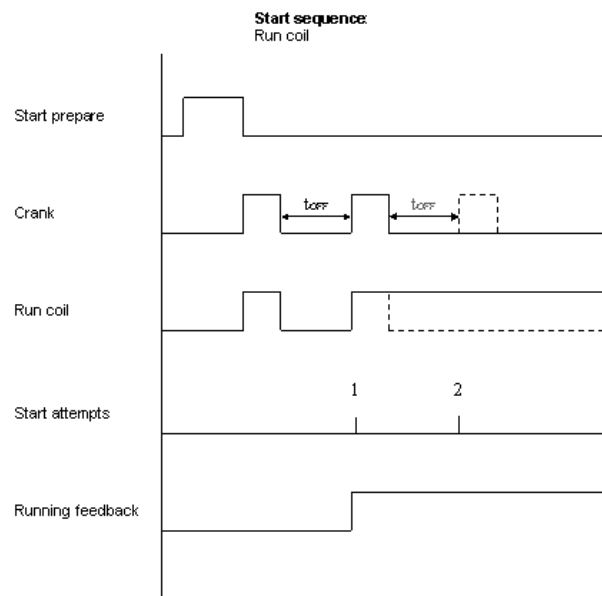

Interruption of start sequence

The start sequence is interrupted in the following situations:

Event	Comment
Stop signal	
Start failure	
Running feedback	Digital input
Running feedback	Tacho set point, menu 4351
Measurements	Frequency measurement above 30Hz The frequency measurement requires a voltage measurement of 30% of U_{NOM}
Emergency stop	
Alarm	Alarms that activate relay 9 (shutdown gen-set)
Stop push-button on display	Only in local
Stop command	'Start sync./control' deactivated through Modbus/CANopen/Profibus



The only protections that can stop the gen-set/interrupt the start sequence when the 'shutdown override' input is activated, are the 'emergency stop' and the 'overspeed'. Both of these must be configured to relay 9.

Start failure alarm (4370 Start attempts)

The start failure alarm occurs if the gen-set has not started after the last start attempt. Output A (OA) and output B (OB) in this menu indicate the relay output(s) which will be activated at a start failure alarm.

Start prepare (4360 Starter)

The start prepare timer can be used for start preparation purposes, e.g. pre-lubrication or pre-heating.



Adjust the time of the start prepare timer to zero seconds if it is not necessary to use the function.

Stop sequence

The drawings illustrate the stop sequence.

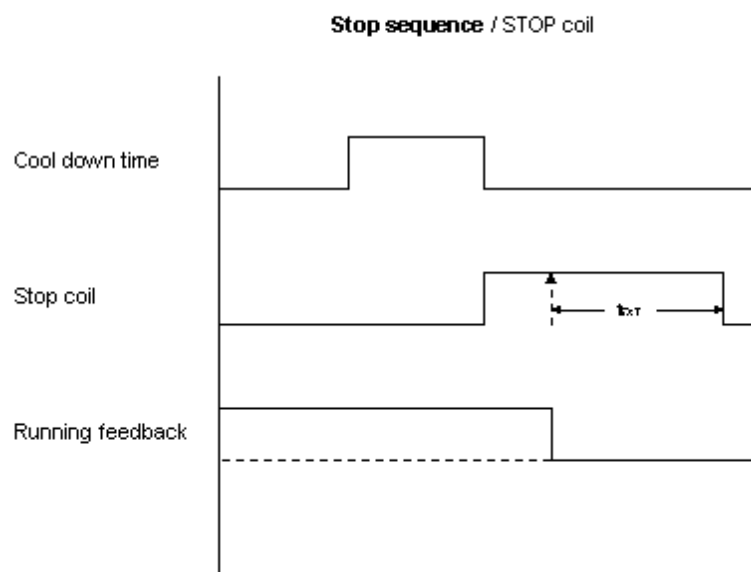
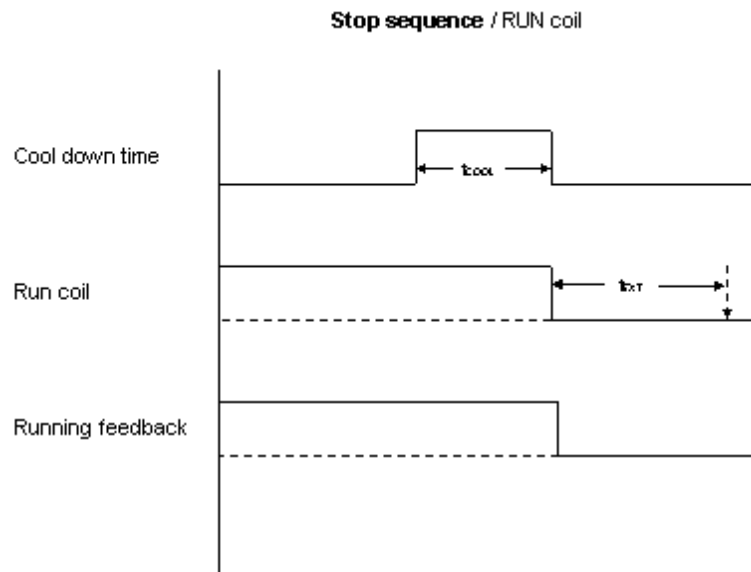

When the stop signal activates (running coil deactivated or stop coil activated) and the circuit breaker is closed, the GPC/PPU will issue an open breaker signal to prevent reverse power.

This means that in case of a shutdown, the breaker is opened simultaneously.

Stop sequence, description

The stop sequence will be activated if a stop command is given. The stop sequence includes the cooling-down time if the stop is a normal or controlled stop.

Description	Cooling-down	Stop	Comment
Remote mode stop	X	X	Deactivate 'Start sync./control' to stop
Stop button on display		X	Local mode
Emergency stop		X	Engine shuts down and GB opens

The stop sequence can only be interrupted during the cooling-down period. Interruptions can occur in these situations:

Event	Comment
Start button is pressed	Local mode: Engine will run in idle speed
Binary 'Start sync./control' input	Remote mode, regulation activated
CB close button is pressed	Local mode only



The stop sequence can only be interrupted during the cooling-down period.



When the engine is stopped, the speed governor output is reset to the offset value if option E1 or EF2 is selected, or the initial value if option EF3 is selected and the PWM output is used. Please refer to the descriptions of the mentioned options.

Stop failure alarm (4410 Stop failure)

A stop failure alarm will occur if the running feedback or the generator voltage and frequency are still active. Output A (OA) and output B (OB) in this menu indicate the relay output(s) that will be activated at a stop failure alarm.

Synchronising

The synchroniser is described in the Designer's Reference Handbook.



Synchronising is only possible in the GPC and PPU.

Generator type



This chapter concerns the GPC and the PPU. The generator type cannot be selected in the GPU.

The GPC/PPU with option M2 can control the closing of a breaker for an asynchronous generator (also called induction generator). In menu 4941 the selection of the asynchronous generator is made.

The factory selection is the synchronous generator.

Running feedback

The tacho input must be used when the asynchronous generator is used. The start and operation of the generator requires that the nominal speed is adjusted (e.g. 1500 or 1800 RPM) as well as the slip frequency which is adjusted in the range $\pm 10\% * RPM_{NOM}$.

Breaker closing

When the gen-set is running, the CB can be closed in local or remote mode. (Please see the description on page 9 regarding breaker operations.) The speed set point will be changed to the nominal RPM \pm the adjusted slip frequency when the close CB sequence is started:

$$RPM_{CB\ CLOSE} = RPM_{NOM} + RPM_{SLIP}$$

When the speed set point is reached, the close CB signal is issued.

4. Display units

GPU display

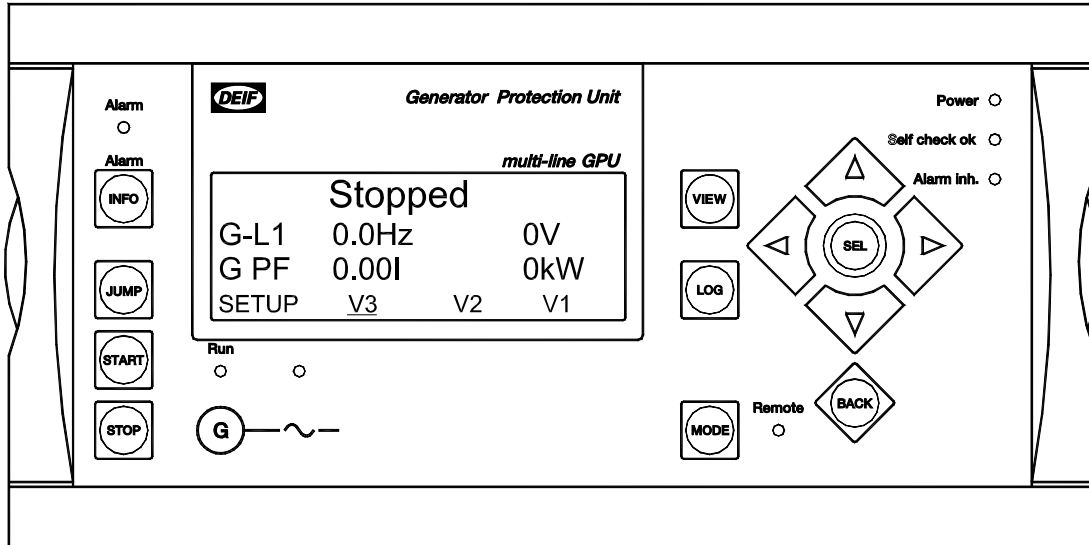

PPU display

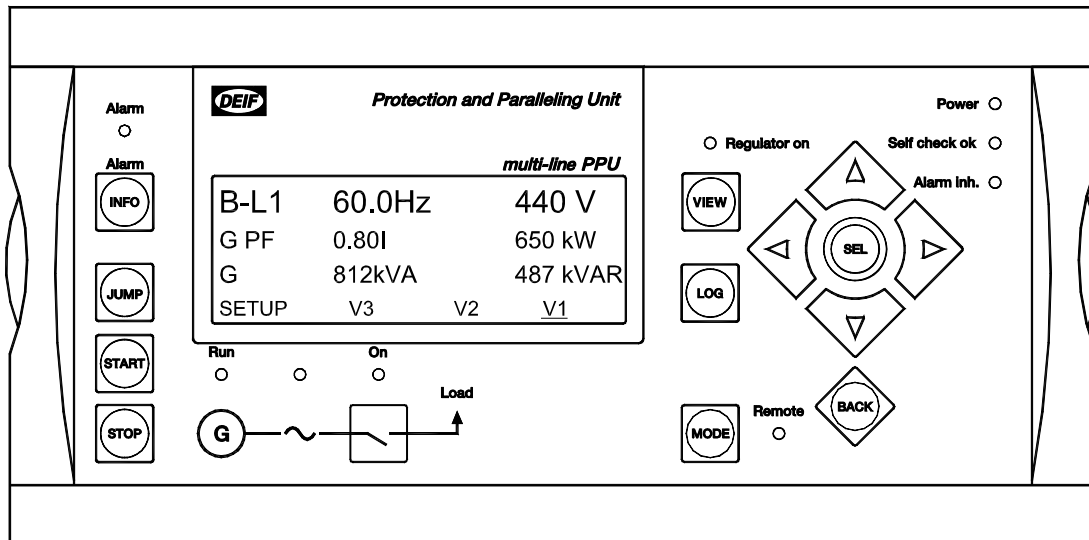

Not M20



Please see the Designer's Reference Handbook to see the display layout.

5. Additional functions

Inhibit

The inhibit functionality is described in the Designer's Reference Handbook. The functionality can be modified according to the requirements of the specific application.

The configuration of the alarms concerning option M2 is done in the inhibit configuration dialog box from the PC utility software. (Select the menu Settings/Inhibits).

In the dialog box the 'Engine interface card' concerns the inhibition of the alarms contained in option M2.

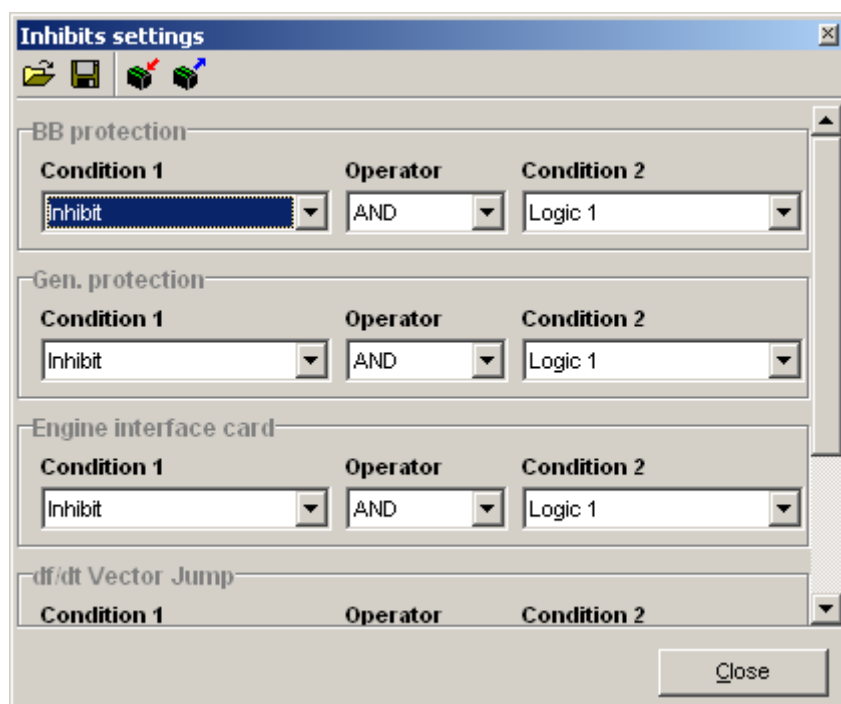

Please refer to the Designer's Reference Handbook for an explanation of the correlation between condition 1/condition 2/operator.

Conditions

The following conditions exist:

	Available in condition 1	Available in condition 2	Comment
Inhibit	X		Digital input terminal 23
Not inhibit	X		Digital input terminal 23
CB open		X	Circuit breaker open terminal 54
CB closed		X	Circuit breaker closed terminal 55
Not running ($U < 30\%$)	X		Measured voltage below $30\% \times U_{NOM}$
Logic 0		X	False logic condition
Logic 1	X		True logic condition



Note that the contents of 'Condition 1' and 'Condition 2' differ.



'CB open' and 'CB closed' cannot be used in the GPU, since these inputs are not available.

Status outputs

Status outputs are used to indicate the present condition of the Multi-line 2. The following outputs are available:

Status output	Description	Comment
4420 Run status	Engine running	Running feedback or $f > 30\text{Hz}$
4430 Remote status	Multi-line 2 is in 'Remote'	Also indicated by LED on the display
4440 Generator ready	These conditions must be true to activate the output: <ul style="list-style-type: none"> No alarms blocking start No breaker failure failure (not GPU) No synchronising failure (not GPU) Remote selected Start enable (if used) 	



The number of available relay outputs is option dependent.

Relay selection

There are relays with dedicated functions (open breaker/stop gen-set). The following relays available in the GPU/GPC/PPU with option M2 can be used without interfering with functions:

Relays	GPU	GPC	PPU
Relay 1	X	X	X
Relay 2	X	X	X
Relay 3	X	X	X
Relay 4	X	No	No
Relay 5	Not available	X	X
Relay 6	Not available	X	X
Relay 7	Not available	X	X
Relay 8	Not available	X	X
Relay 9	No	No	No



Option M14 gives another 4 relays.

Digital input

The inputs can be configured in the PC utility software. The following functions are special for option M2.

Terminal \ Input function	Local	Remote	Input type Constant/pulse
110			
111			
112			
113			
114	X	X	Constant
115	X	X	Constant
116	X	X	Constant
117			
118	X	X	Constant

Functional description

Digital input 110 (terminal 110)

This input is fully configurable as alarm input.

Digital input 111 (terminal 111)

This input is fully configurable as alarm input.

Digital input 112 (terminal 112)

This input is fully configurable as alarm input.

Digital input 113 (terminal 113)

This input is fully configurable as alarm input.

Shutdown override (terminal 114)



Shutdown override is also called 'fire pump mode' in previous versions of the PC utility software.



The shutdown override function will, when activated, disable all shutdown functions except 'emergency stop' and 'overspeed'.

The purpose of the shutdown override is to let the gen-set run without being able to stop due to failure situations (alarms). The alarms will still be indicated in the alarm list, but there will be no shutdowns.



The number of start attempts is changed to nine attempts when the 'shutdown override' is activated.



The engine and generator is not protected when this input is activated and will, as a consequence of this, not stop in case of a serious alarm.

Start enable (terminal 115)

The start enable input is used to allow or block the start of the engine. When the input is high the engine can be started, but when it is low the start request will be ignored.

The start enable input can be deactivated after the gen-set has started. If the input is deactivated before the running feedback is present, the start sequence is interrupted.

Running (terminal 116)

The digital running feedback will stop the start sequence of the gen-set. At the same time, the timer of menu 2290 'Delay regulation' will be started.

Digital input 117 (terminal 117)

This input is fully configurable as alarm input.



The input is configured as an alarm input as default. The text used is 'engine failure'.

Emergency stop (terminal 118)

The emergency stop will trip the relays #4 (open breaker) and #9 (stop gen-set) in the GPC and PPU.



This input is configured as a normally closed input.

Configuration

The input functions are activated using a binary input. The input must be chosen in the PC utility software (select the menu Settings, Inputs/Outputs, or press the icon on the horizontal toolbar).

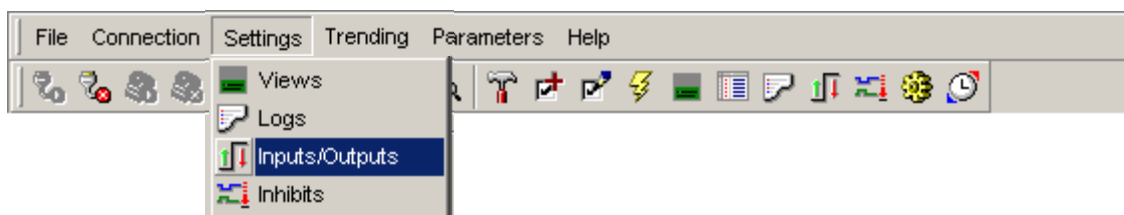

When selecting 'Inputs/Outputs', this dialog box appears:

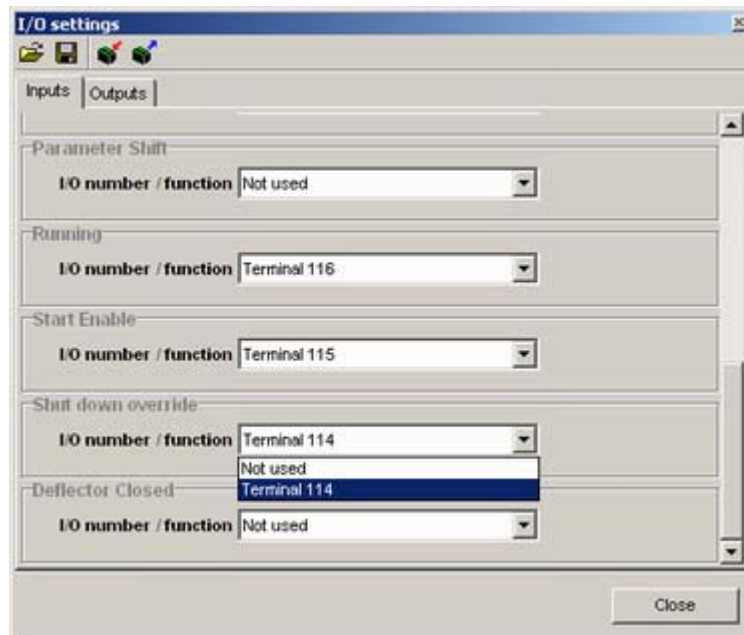

In the above configuration example, the 'Shutdown override' is adjusted to terminal 114.

Input alarm function high/low

Digital input alarms can be configured with a possibility to select when the alarms are to be activated. The possible selections of the input function are 'High alarm' (normally open) or 'Low alarm' (normally closed).



The PC utility software must be used to configure high/low alarm. The display cannot be used.

The drawing below illustrates a digital input used as an alarm input.

1. Digital input alarm configured to 'Low alarm', normally closed
This will initiate an alarm when the signal on the digital input disappears.
2. Digital input alarm configured to 'High alarm', normally open
This will initiate an alarm when the signal on the digital input appears.



The relay output function cannot be changed. This will always be a deenergised relay, and it will energise when the alarm occurs.

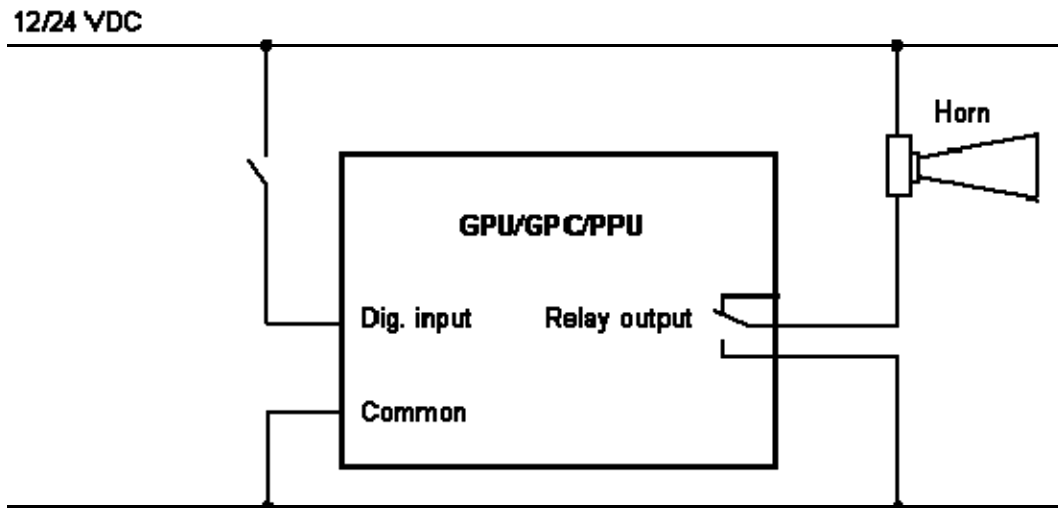

Only relays 1-4 have three connections. All other relays are NO relays with only two connections.

VDO inputs

As there are different types of VDO resistor sensors, the settings of the characteristics of the specific type must be made. This characteristic is made by defining 8 break points for each sensor, enabling different characteristics to be used.

The 3 inputs are pre-defined for pressure (1), temperature (2) and fuel tank level (3). The alarm texts can be changed in the PC utility software.

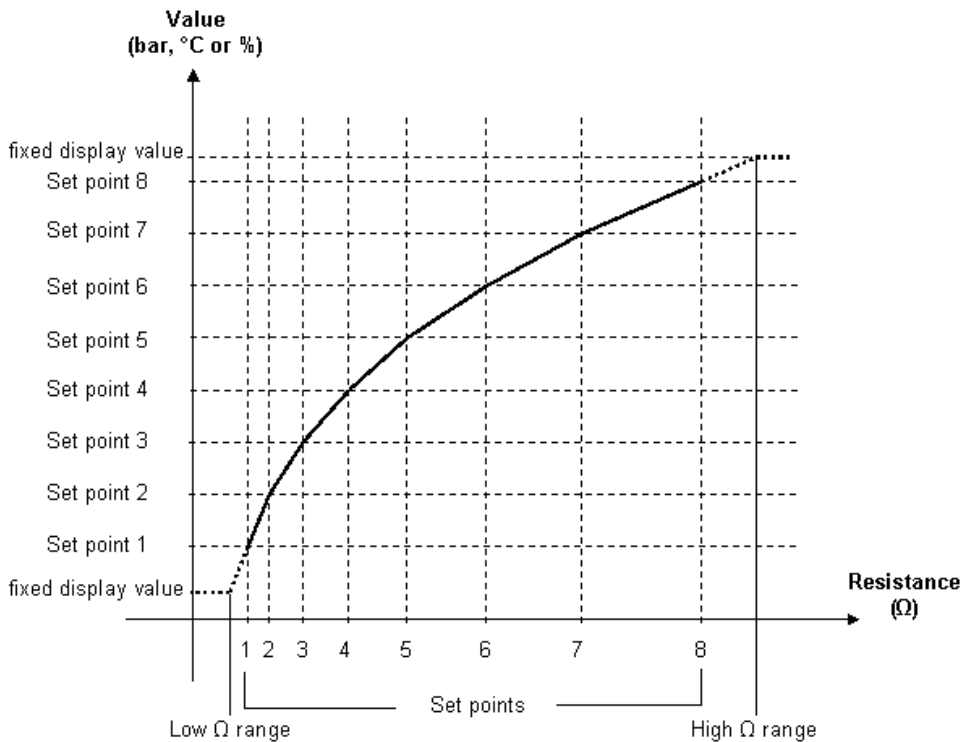



The software extends the measuring in a linear manner (when the measurement lies outside the chosen range) using the slope of the curve between points 1-2 or 7-8. When the end of the total resistance range of the input is reached, the readout in the display 'freezes' at this point.



The alarm setting range for temperature is extending all the way up to 150°C even though the curve setting range is max. 110°C.



The 8 curve settings for VDO nos. 1, 2 and 3 cannot be changed in the display, but only in the PC utility software. The alarm settings can be changed in both display and PC utility software.

Configuration

The 8 curve settings for the configurable VDO inputs cannot be changed in the display, but **only** in the PC utility software. The alarm settings can be changed both in the display and in the PC utility software. In the PC utility software, the configurable inputs are adjusted in this dialog box:

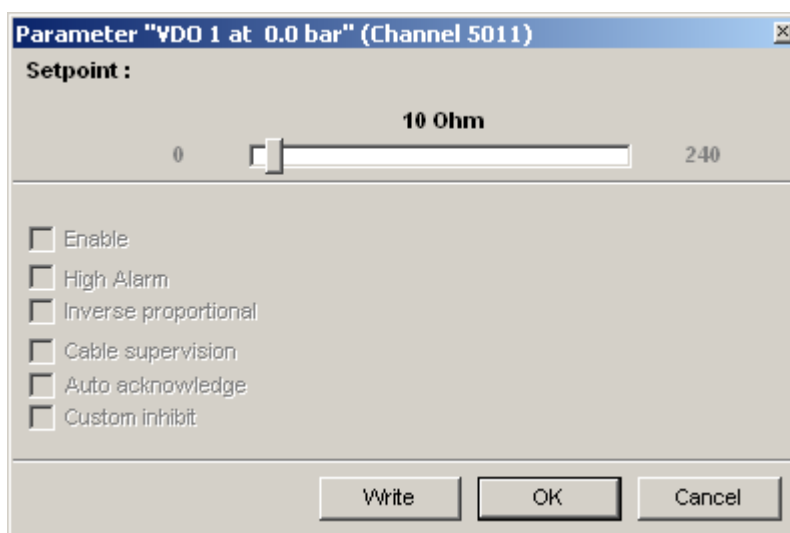

Adjust the resistance of the VDO sensor at the specific measuring value. In the example above, the adjustment is 10Ω at 0.0 bar.

Running feedback

The Multi-line 2 requires a running feedback when the gen-set is running. Two selections are possible (only one is necessary for proper operation):

1. Digital feedback (terminal 116)
2. Tacho signal (terminal 108/109)



If the running feedback is not connected, a 'tacho failure' alarm occurs in the display.



If the tacho input is not used, the digital input must be used. Otherwise, the starter motor may be damaged.

Digital input

To use the digital input, terminal 116 is used. The factory setting of terminal 116 is 'Running feedback'.

If the setting must be changed, please refer to the procedure on page 25.

Tacho input

The tacho input is intended for a magnetic 2-wire pick-up.

Three settings concern the configuration of the tacho input:

Set point		Description	Comment
4351	Running speed limit	This is the set point where the ML-2 detects running. At this point the starter motor will be disengaged.	
4352	Number of teeth	This is the number of teeth that is present on the flywheel of the engine.	Must be adjusted to zero, if the tacho is not used for running detection.
4353	Nominal RPM	This is the nominal revolutions of the gen-set.	Only used when generator type is selected to 'asynchronous'.

Delay regulation

When the gen-set is started it can, on certain occasions, be necessary to delay the regulation of the GPC/PPU. This can be done in the menu 2290, 'Delay regulation'.

'Delay regulation' includes two functions and they can be used in the Multi-line units as described in the table:

Product	GPU	GPC	PPU
Function			
Delay of the start of the regulation		X	X
Relay activation	X	X	X

Configuration

The menu consists of four parameters. The table shows which parameter that needs to be adjusted depending on whether the required function is delayed regulation or relay activation.

Function		Delay regulation	Activate relay output
Menu			
2291	Timer	X	X
2292	Output A		X
2293	Output B		X
2294	Enable		X



Only the timer setting must be configured if the required function is delayed regulation.

Delay of the start of the regulation

This is illustrated on the diagram below. It is seen that the regulation is started a certain time after the frequency increases above 30Hz.

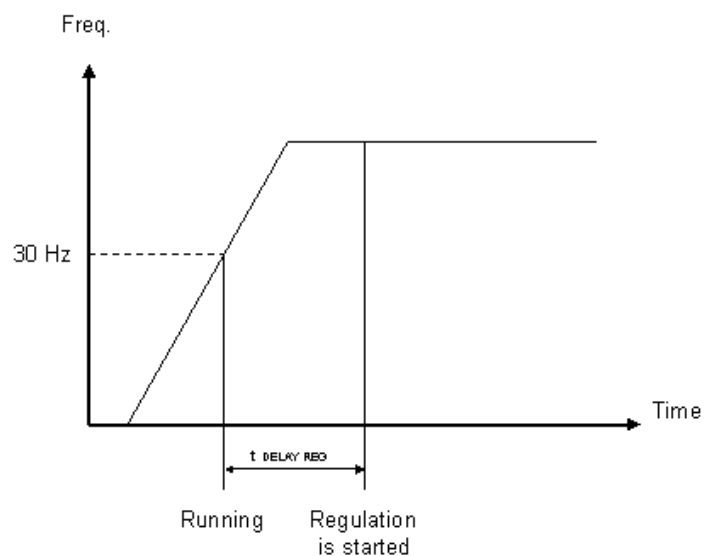



The delay regulation function looks at the frequency.

Running feedback from the tacho, engine communication or digital inputs cannot be used for this function.

Relay activation

It is possible to activate a relay output when the regulation is started in the GPC and the PPU. In the GPU, menu '2290 Delay regulation' also exists but the function is limited to activate a relay. The reason is that the GPU does not include regulation functionality of the gen-set.

When delayed regulation is needed, output A and output B are typically adjusted to the same relay and the function is enabled.



To avoid an alarm when the relay activates, the specific relay must be selected to be a limit relay.

Modbus/Profibus/CANopen

If the Multi-line 2 is equipped with an option for external communication (Modbus, Profibus or CANopen), the operation of the gen-set can be controlled when 'Remote' mode is selected.

To get control through communication, the digital input on terminal 26 'Ext. comm. control' must be activated.



Even though the engine logic is controlled through communication, the digital 'start enable' (terminal 115) must still be activated (if used).

3. Parameter list

The setup of parameters is done via the display or the PC utility software (USW).



For further information about the structure of the parameter descriptions, please see the Designer's Reference Handbook.

Digital input setup

3280 Dig. input 110

No.	Setting		Min. setting	Max. setting	Factory setting
3281	Dig. input 110	Timer	0.0 s	100.0 s	10.0 s
3282	Dig. input 110	Relay output A	R0 (none)	Option dependent	R0 (none)
3283	Dig. input 110	Relay output B	R0 (none)		R0 (none)
3284	Dig. input 110	Enable	OFF	ON	OFF

3290 Dig. input 111

No.	Setting		Min. setting	Max. setting	Factory setting
3291	Dig. input 111	Timer	0.0 s	100.0 s	10.0 s
3292	Dig. input 111	Relay output A	R0 (none)	Option dependent	R0 (none)
3293	Dig. input 111	Relay output B	R0 (none)		R0 (none)
3294	Dig. input 111	Enable	OFF	ON	OFF

3300 Dig. input 112

No.	Setting		Min. setting	Max. setting	Factory setting
3301	Dig. input 112	Timer	0.0 s	100.0 s	10.0 s
3302	Dig. input 112	Relay output A	R0 (none)	Option dependent	R0 (none)
3303	Dig. input 112	Relay output B	R0 (none)		R0 (none)
3304	Dig. input 112	Enable	OFF	ON	OFF

3310 Dig. input 113

No.	Setting		Min. setting	Max. setting	Factory setting
3311	Dig. input 113	Timer	0.0 s	100.0 s	10.0 s
3312	Dig. input 113	Relay output A	R0 (none)	Option dependent	R0 (none)
3313	Dig. input 113	Relay output B	R0 (none)		R0 (none)
3314	Dig. input 113	Enable	OFF	ON	OFF

3320 Dig. input 114

No.	Setting		Min. setting	Max. setting	Factory setting
3321	Dig. input 114	Timer	0.0 s	100.0 s	10.0 s
3322	Dig. input 114	Relay output A	R0 (none)	Option dependent	R0 (none)
3323	Dig. input 114	Relay output B	R0 (none)		R0 (none)
3324	Dig. input 114	Enable	OFF	ON	OFF

3330 Dig. input 115

No.	Setting		Min. setting	Max. setting	Factory setting
3331	Dig. input 115	Timer	0.0 s	100.0 s	10.0 s
3332	Dig. input 115	Relay output A	R0 (none)	Option dependent	R0 (none)
3333	Dig. input 115	Relay output B	R0 (none)		R0 (none)
3334	Dig. input 115	Enable	OFF	ON	OFF

3340 Dig. input 116

No.	Setting		Min. setting	Max. setting	Factory setting
3341	Dig. input 116	Timer	0.0 s	100.0 s	10.0 s
3342	Dig. input 116	Relay output A	R0 (none)	Option dependent	R0 (none)
3343	Dig. input 116	Relay output B	R0 (none)		R0 (none)
3344	Dig. input 116	Enable	OFF	ON	OFF

3350 Engine failure (terminal 117)

No.	Setting		Min. setting	Max. setting	Factory setting
3351	Engine fail	Timer	0.0 s	100.0 s	10.0 s
3352	Engine fail	Relay output A	R0 (none)	Option dependent	R0 (none)
3353	Engine fail	Relay output B	R0 (none)		R0 (none)
3354	Engine fail	Enable	OFF	ON	OFF

3360 Emergency STOP (terminal 118)

No.	Setting		Min. setting	Max. setting	Factory setting
3361	Emergency STOP	Timer	0.0 s	100.0 s	10.0 s
3362	Emergency STOP	Relay output A	R0 (none)	Option dependent	R0 (none)
3363	Emergency STOP	Relay output B	R0 (none)		R0 (none)
3364	Emergency STOP	Enable	OFF	ON	OFF

Analogue input setup**3440 4...20mA input 1.1**

No.	Setting		Min. setting	Max. setting	Factory setting
3441	4...20mA input 1.1	Set point	4mA	20mA	10mA
3442	4...20mA input 1.1	Timer	0.2 s	100.0 s	10.0 s
3443	4...20mA input 1.1	Relay output A	R0 (none)	Option dependent	R0 (none)
3444	4...20mA input 1.1	Relay output B	R0 (none)		R0 (none)
3445	4...20mA input 1.1	Enable	OFF	ON	OFF

3450 4...20mA input 1.2

No.	Setting		Min. setting	Max. setting	Factory setting
3451	4...20mA input 1.2	Set point	4mA	20mA	10mA
3452	4...20mA input 1.2	Timer	0.2 s	100.0 s	10.0 s
3453	4...20mA input 1.2	Relay output A	R0 (none)	Option dependent	R0 (none)
3454	4...20mA input 1.2	Relay output B	R0 (none)		R0 (none)
3455	4...20mA input 1.2	Enable	OFF	ON	OFF

3460 4...20mA input 2.1

No.	Setting		Min. setting	Max. setting	Factory setting
3461	4...20mA input 2.1	Set point	4mA	20mA	10mA
3462	4...20mA input 2.1	Timer	0.2 s	100.0 s	10.0 s
3463	4...20mA input 2.1	Relay output A	R0 (none)	Option dependent	R0 (none)
3464	4...20mA input 2.1	Relay output B	R0 (none)		R0 (none)
3465	4...20mA input 2.1	Enable	OFF	ON	OFF

3470 4...20mA input 2.2

No.	Setting		Min. setting	Max. setting	Factory setting
3471	4...20mA input 2.2	Set point	4mA	20mA	10mA
3472	4...20mA input 2.2	Timer	0.2 s	100.0 s	10.0 s
3473	4...20mA input 2.2	Relay output A	R0 (none)	Option dependent	R0 (none)
3474	4...20mA input 2.2	Relay output B	R0 (none)		R0 (none)
3475	4...20mA input 2.2	Enable	OFF	ON	OFF

3480 4...20mA input 3.1

No.	Setting		Min. setting	Max. setting	Factory setting
3481	4...20mA input 3.1	Set point	4mA	20mA	10mA
3482	4...20mA input 3.1	Timer	0.2 s	100.0 s	10.0 s
3483	4...20mA input 3.1	Relay output A	R0 (none)	Option dependent	R0 (none)
3484	4...20mA input 3.1	Relay output B	R0 (none)		R0 (none)
3485	4...20mA input 3.1	Enable	OFF	ON	OFF

3490 4...20mA input 3.2

No.	Setting		Min. setting	Max. setting	Factory setting
3491	4...20mA input 3.2	Set point	4mA	20mA	10mA
3492	4...20mA input 3.2	Timer	0.2 s	100.0 s	10.0 s
3493	4...20mA input 3.2	Relay output A	R0 (none)	Option dependent	R0 (none)
3494	4...20mA input 3.2	Relay output B	R0 (none)		R0 (none)
3495	4...20mA input 3.2	Enable	OFF	ON	OFF

Overspeed alarms**3640 Overspeed 1**

No.	Setting		Min. setting	Max. setting	Factory setting
3641	Overspeed 1	Set point	0 RPM	2000 RPM	1600 RPM
3642	Overspeed 1	Timer	0.2 s	100.0 s	15.0 s
3643	Overspeed 1	Relay output A	R0 (none)	Option dependent	R2 (none)
3644	Overspeed 1	Relay output B	R0 (none)		R0 (none)
3645	Overspeed 1	Enable	OFF	ON	OFF

3650 Overspeed 2

No.	Setting		Min. setting	Max. setting	Factory setting
3651	Overspeed 2	Set point	0 RPM	2000 RPM	1600 RPM
3652	Overspeed 2	Timer	0.2 s	100.0 s	15.0 s
3653	Overspeed 2	Relay output A	R0 (none)	Option dependent	R2 (none)
3654	Overspeed 2	Relay output B	R0 (none)		R0 (none)
3655	Overspeed 2	Enable	OFF	ON	OFF

VDO input – alarm setup**3660 VDO sensor 1, oil pressure 1**

No.	Setting		Min. setting	Max. setting	Factory setting
3661	Oil pressure 1	Set point	0.0 Bar	10.0 Bar	4.0 Bar
3662	Oil pressure 1	Timer	0.2 s	100.0 s	5.0 s
3663	Oil pressure 1	Relay output A	R0 (none)	Option dependent	R0 (none)
3664	Oil pressure 1	Relay output B	R0 (none)		R0 (none)
3665	Oil pressure 1	Enable	OFF	ON	ON



Text (Oil pressure) can be changed using PC utility software. Changing the text in setting 3660 also affects the text in 3670.

3670 VDO sensor 1, oil pressure 2

No.	Setting		Min. setting	Max. setting	Factory setting
3671	Oil pressure 2	Set point	0.0 Bar	10.0 Bar	4.0 Bar
3672	Oil pressure 2	Timer	0.2 s	100.0 s	5.0 s
3673	Oil pressure 2	Relay output A	R0 (none)	Option dependent	R0 (none)
3674	Oil pressure 2	Relay output B	R0 (none)		R0 (none)
3675	Oil pressure 2	Enable	OFF	ON	ON

3680 VDO sensor 2, cooling water temperature 1

No.	Setting		Min. setting	Max. setting	Factory setting
3681	Cool W temp. 1	Set point	0°C	150°C	100°C
3682	Cool W temp. 1	Timer	0.2 s	100.0 s	5.0 s
3683	Cool W temp. 1	Relay output A	R0 (none)	Option dependent	R0 (none)
3684	Cool W temp. 1	Relay output B	R0 (none)		R0 (none)
3685	Cool W temp. 1	Enable	OFF	ON	ON



Text (Cool water temp.) can be changed using PC utility software. Changing the text in setting 3680 also affects the text in 3690.

3690 VDO sensor 2, cooling water temperature 2

No.	Setting		Min. setting	Max. setting	Factory setting
3691	Cool W temp. 2	Set point	0°C	150°C	100°C
3692	Cool W temp. 2	Timer	0.2 s	100.0 s	5.0 s
3693	Cool W temp. 2	Relay output A	R0 (none)	Option dependent	R0 (none)
3694	Cool W temp. 2	Relay output B	R0 (none)		R0 (none)
3695	Cool W temp. 2	Enable	OFF	ON	ON

3700 VDO sensor 3, fuel level 1

No.	Setting		Min. setting	Max. setting	Factory setting
3701	Fuel level 1	Set point	0%	100%	10%
3702	Fuel level 1	Timer	0.2 s	100.0 s	10.0 s
3703	Fuel level 1	Relay output A	R0 (none)	Option dependent	R0 (none)
3704	Fuel level 1	Relay output B	R0 (none)		R0 (none)
3705	Fuel level 1	Enable	OFF	ON	ON



Text (Fuel level) can be changed using PC utility software. Changing the text in setting 3700 also affects the text in 3710.

3710 VDO sensor 3, fuel level 2

No.	Setting		Min. setting	Max. setting	Factory setting
3711	Fuel level 2	Set point	0%	100%	10%
3712	Fuel level 2	Timer	0.2 s	100.0 s	10.0 s
3713	Fuel level 2	Relay output A	R0 (none)	Option dependent	R0 (none)
3714	Fuel level 2	Relay output B	R0 (none)		R0 (none)
3715	Fuel level 2	Enable	OFF	ON	ON

Magnetic pick-up setup**4350 Tacho configuration**

No.	Setting		Min. setting	Max. setting	Factory setting
4351	Tacho config.	Running speed	1 RPM	2000 RPM	300 RPM
4352	Tacho config.	No. of teeth	0 teeth	400 teeth	0 teeth
4353	Tacho config.	Nominal speed	1 RPM	4000 RPM	1500 RPM

Start control setup**4360 Starter control**

No.	Setting		Min. setting	Max. setting	Factory setting
4361	Starter	Start prepare	0.0 s	600.0 s	5.0 s
4362	Starter	Start ON time	1.0 s	30.0 s	5.0 s
4363	Starter	Start OFF time	1.0 s	99.0 s	5.0 s

4370 Start attempts

No.	Setting		Min. setting	Max. setting	Factory setting
4371	Start attempts	Attempts	1	10	3
4372	Start attempts	Relay output A	R0 (none)	Option dependent	R0 (none)
4373	Start attempts	Relay output B	R0 (none)		R0 (none)

4380 f/U OK

No.	Setting		Min. setting	Max. setting	Factory setting
4381	f/U OK	Timer	1.0 s	99.0 s	5.0 s

4390 f/U failure

No.	Setting		Min. setting	Max. setting	Factory setting
4391	f/U failure	Timer	1.0 s	99.0 s	5.0 s
4392	f/U failure	Relay output A	R0 (none)	Option dependent	R0 (none)
4393	f/U failure	Relay output B	R0 (none)		R0 (none)

Stop control setup**4400 STOP**

No.	Setting		Min. setting	Max. setting	Factory setting
4401	STOP	Cool down time	0.0 s	999.0 s	240.0 s
4402	STOP	Extended STOP	1.0 s	99.0 s	5.0 s
4403	STOP	Coil type	STOP (0)	RUN (1)	STOP (0)

4410 Stop failure

No.	Setting		Min. setting	Max. setting	Factory setting
4411	Stop failure	Timer	10.0 s	3000.0 s	30.0 s
4412	Stop failure	Relay output A	R0 (none)	Option dependent	R0 (none)
4413	Stop failure	Relay output B	R0 (none)		R0 (none)

Status outputs**4420 Run status**

No.	Setting		Min. setting	Max. setting	Factory setting
4421	Run status	Timer	0.0 s	3000.0 s	0.5 s
4422	Run status	Relay output A	R0 (none)	Option dependent	R0 (none)
4423	Run status	Relay output B	R0 (none)		R0 (none)
4424	Run status	Enable	OFF	ON	OFF

4430 Remote status

No.	Setting		Min. setting	Max. setting	Factory setting
4431	Remote mode	Timer	1.0 s	10.0 s	0.5 s
4432	Remote mode	Relay output A	R0 (none)	Option dependent	R0 (none)
4433	Remote mode	Relay output B	R0 (none)		R0 (none)
4434	Remote mode	Enable	OFF	ON	OFF

4440 Generator ready

No.	Setting		Min. setting	Max. setting	Factory setting
4441	Generator ready	Timer	1.0 s	10.0 s	0.5 s
4442	Generator ready	Relay output A	R0 (none)	Option dependent	R0 (none)
4443	Generator ready	Relay output B	R0 (none)		R0 (none)
4444	Generator ready	Enable	OFF	ON	OFF

Generator type**4940 Generator type selection**

No.	Setting		Min. setting	Max. setting	Factory setting
4941	Generator type	Asynchron. sync. ON/OFF	OFF	ON	OFF
4942	Generator type	Slip frequency	-10.0%	10.0%	1.0%

VDO characteristic setup**5010 VDO sensor 1, first set of parameters**

No.	Setting		Min. setting	Max. setting	Factory setting
5011	VDO 1.1	0 (Bar)	0 Ohm	2500 Ohm	100 Ohm
5012	VDO 1.2	2.5 (Bar)	0 Ohm	2500 Ohm	449 Ohm
5013	VDO 1.3	5 (Bar)	0 Ohm	2500 Ohm	810 Ohm
5014	VDO 1.4	6 (Bar)	0 Ohm	2500 Ohm	1347 Ohm

5020 VDO sensor 1, second set of parameters

No.	Setting		Min. setting	Max. setting	Factory setting
5021	VDO 1.5	7 (Bar)	0 Ohm	2500 Ohm	1840 Ohm
5022	VDO 1.6	8 (Bar)	0 Ohm	2500 Ohm	2000 Ohm
5023	VDO 1.7	9 (Bar)	0 Ohm	2500 Ohm	2100 Ohm
5024	VDO 1.8	10 (Bar)	0 Ohm	2500 Ohm	2200 Ohm

5030 VDO sensor 2, first set of parameters

No.	Setting		Min. setting	Max. setting	Factory setting
5031	VDO 2.1	40 (°C)	0 Ohm	500 Ohm	292 Ohm
5032	VDO 2.2	50 (°C)	0 Ohm	500 Ohm	197 Ohm
5033	VDO 2.3	60 (°C)	0 Ohm	500 Ohm	134 Ohm
5034	VDO 2.4	70 (°C)	0 Ohm	500 Ohm	97 Ohm

5040 VDO sensor 2, second set of parameters

No.	Setting		Min. setting	Max. setting	Factory setting
5041	VDO 2.5	80 (°C)	0 Ohm	500 Ohm	70 Ohm
5042	VDO 2.6	90 (°C)	0 Ohm	500 Ohm	51 Ohm
5043	VDO 2.7	100 (°C)	0 Ohm	500 Ohm	39 Ohm
5044	VDO 2.8	110 (°C)	0 Ohm	500 Ohm	29 Ohm

5050 VDO sensor 3, first set of parameters

No.	Setting		Min. setting	Max. setting	Factory setting
5051	VDO 3.1	0%	0 Ohm	200 Ohm	78.8 Ohm
5052	VDO 3.2	40%	0 Ohm	200 Ohm	47.9 Ohm
5053	VDO 3.3	50%	0 Ohm	200 Ohm	40.2 Ohm
5054	VDO 3.4	60%	0 Ohm	200 Ohm	32.5 Ohm

5060 VDO sensor 3, second set of parameters

No.	Setting		Min. setting	Max. setting	Factory setting
5061	VDO 3.5	70%	0 Ohm	200 Ohm	24.8 Ohm
5062	VDO 3.6	80%	0 Ohm	200 Ohm	17.0 Ohm
5063	VDO 3.7	90%	0 Ohm	200 Ohm	9.3 Ohm
5064	VDO 3.8	100%	0 Ohm	200 Ohm	1.6 Ohm

DEIF A/S reserves the right to change any of the above