

## Description of options

### Option M13 Conf. I/O ext. card – 7 binary inputs Multi-line 2 – version 2

4189340283C  
SW 2.4X.X

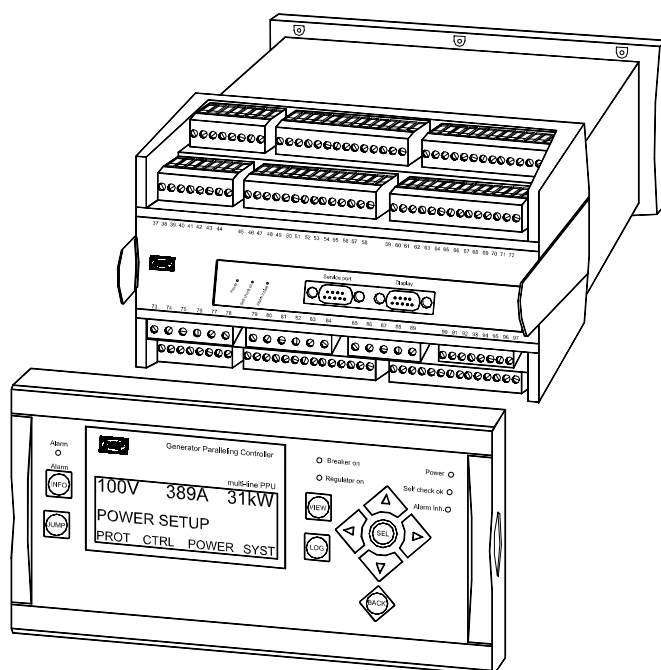

- *Description of option*
- *Functional description*
- *Parameter list*

CE

## Table of contents

<b>1. WARNINGS AND LEGAL INFORMATION.....</b>	<b>3</b>
ELECTROSTATIC DISCHARGE AWARENESS .....	3
SAFETY ISSUES.....	3
DEFINITIONS .....	3
<b>2. DESCRIPTION OF OPTIONS .....</b>	<b>4</b>
M13 OPTION .....	4
TERMINAL DESCRIPTION .....	4
DC WIRING .....	4
<b>3. FUNCTIONAL DESCRIPTION.....</b>	<b>5</b>
BINARY INPUT .....	5
ALARMS.....	5
INPUT FUNCTION SELECTION .....	5
CONFIGURATION .....	7
<b>4. PARAMETER LIST .....</b>	<b>9</b>

**This manual is valid for standard multi-line 2 PPU/GPU/GPC units with firmware version 2.20.0 or later.**

## 1. Warnings and legal information

---

DEIF takes no responsibility for installation or operation of the generator set. If there is any doubt about how to install or operate the generator set controlled by the unit, the company responsible for the installation or the operation of the set must be contacted.

**The units are not to be opened by unauthorised personnel. If opened anyway, the warranty will be lost.**

### Electrostatic discharge awareness

Sufficient care must be taken to protect the terminals against static discharges during the installation. Once the unit is installed and connected, these precautions are no longer necessary.

### Safety issues

Installing the unit implies work with dangerous currents and voltages. Therefore, the installation should only be carried out by authorised personnel who understand the risks involved in working with live electrical equipment.



**Be aware of the hazardous live currents and voltages. Do not touch any AC measurement inputs as this could lead to injury or death.**

### Definitions

Throughout this document a number of notes and warnings will be presented. To ensure that these are noticed, they will be highlighted in order to separate them from the general text.

### Notes



**The notes provide general information which will be helpful for the reader to bear in mind.**

### Warning



**The warnings indicate a potentially dangerous situation which could result in death, personal injury or damaged equipment, if certain guidelines are not followed.**

## 2. Description of options

### M13 option

Option M13 is a hardware option, and therefore a separate PCB is installed in slot #8 in addition to the standard-installed hardware.

Option M13 covers the following ANSI code:

Function	ANSI no.
7 x binary inputs for control and/or alarms	77

### Terminal description

Term.	Function	Technical data	Description
126	Com.	Common	Common for terminals 127-133
127	Binary input 127	Optocoupler	Configurable
128	Binary input 128	Optocoupler	Configurable
129	Binary input 129	Optocoupler	Configurable
130	Binary input 130	Optocoupler	Configurable
131	Binary input 131	Optocoupler	Configurable
132	Binary input 132	Optocoupler	Configurable
133	Binary input 133	Optocoupler	Configurable

### DC wiring

The wiring is done by connecting 12 or 24 volts across the common and the input terminal. All binary inputs are 12/24V DC bi-directional optocoupler. Typical input is:

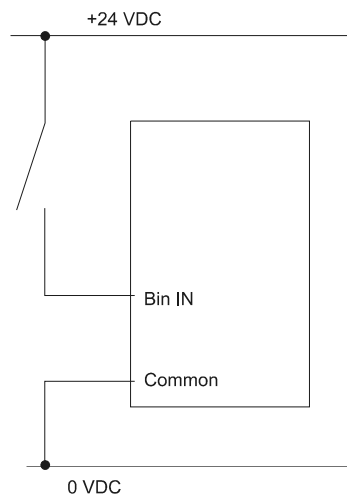

The binary inputs use fixed signals.

### 3. Functional description

#### Binary input

The binary inputs available in this option can be used as alarm inputs. The alarm inputs can be set up through the PC utility software or partly from the display.

The PC utility software is a Windows® based software, which can be downloaded from our website [www.deif.com](http://www.deif.com). To adjust the inputs via the PC utility software, a computer must be connected to the controller unit. Furthermore, the unit parameters must be uploaded to the computer.

#### Alarms

The delay settings are all of the definite time type, i.e. a set time is selected. The timer will be activated if the input goes ON (or OFF if selected to be 'low alarm' in the PC utility software). If the input is reset before the timer runs out, the timer will be reset.

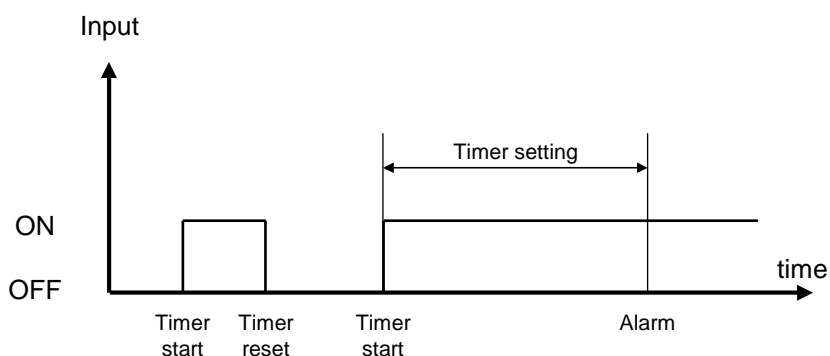

When the timer runs out, the output will be activated.

#### Input function selection

Digital input alarms can be configured with a possibility to select when the alarm is to be activated. The possible selections of the input function are normally open or normally closed.

The drawing below illustrates a digital input used as an alarm input. The input can be configured to activate the relay output in one of the following ways:

1. Digital input alarm configured to NC, normally closed  
*This will activate an alarm, when the signal on the digital input disappears.*  
(PC software = 'low alarm')
2. Digital input alarm configured to NO, normally open,  
*This will activate an alarm, when the signal on the digital input appears.*  
(PC software = 'high alarm')



**The relay output function cannot be changed. It will always be an NO relay that closes, when the alarm occurs, Alarm = CC (closed circuit).**

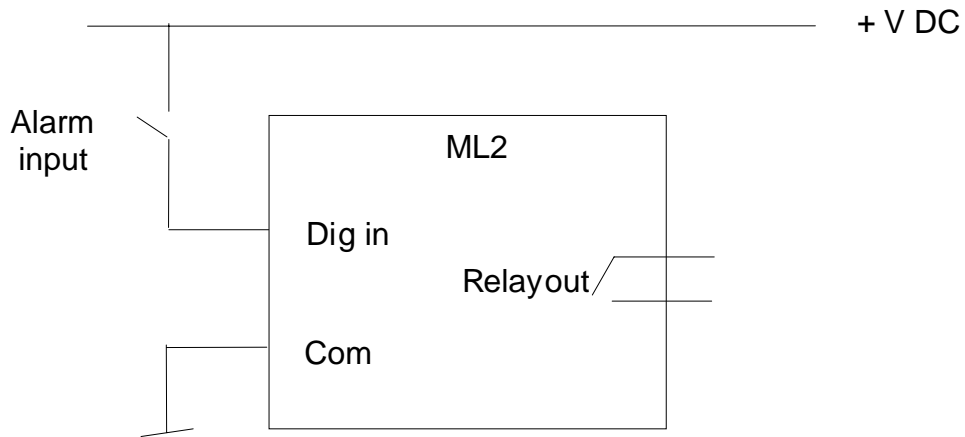

**This adjustment can only be made in the PC utility software. The factory setting is NO.**

## Configuration

The configuration of the digital inputs can be done from the display (except selection of NO/NC) or from the PC utility software.

### Configuration from the utility software

When the configuration of the binary inputs is made from the PC utility software, the configuration is done in a few steps.

In this example, the digital input no. 127 is configured.

Step 1:

Upload the parameters from the multi-line 2.

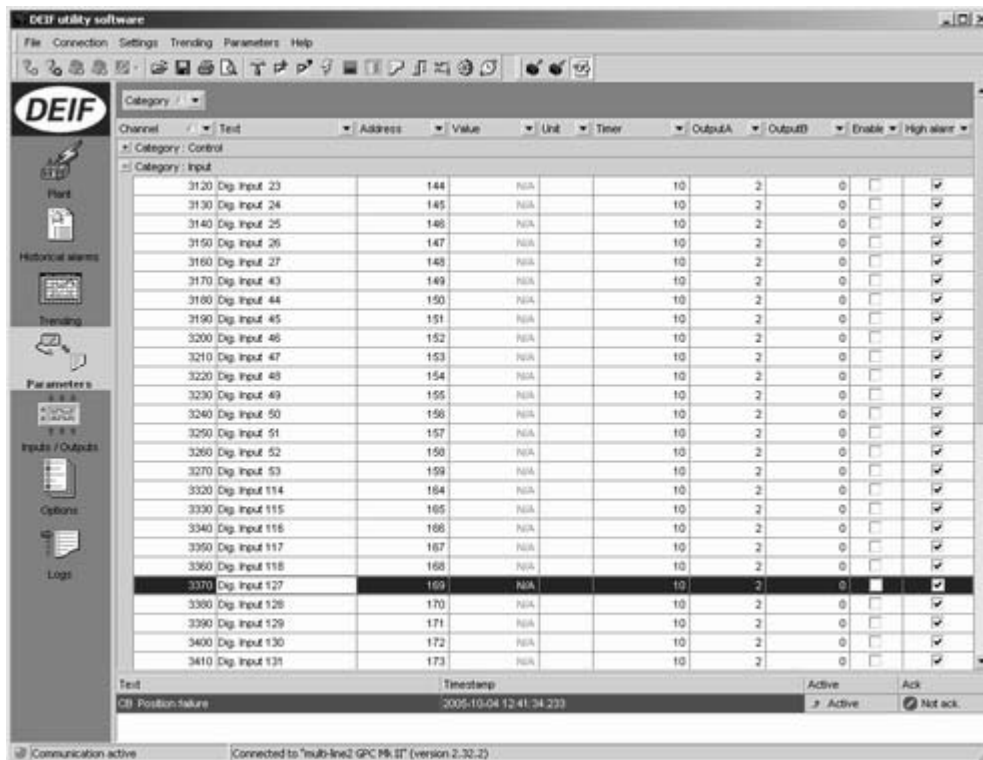

Step 2:

Locate menu 3370 in the list above and double click the marked line. Now, a dialogue box appears and the settings can be adjusted. Write the value to the multi-line 2.

## Adjustments

The set points are described below.

Set point:

The text can be changed by clicking the button  which is placed on the left hand side of the existing text.

Timer

The timer can be adjusted by moving the glider left or right or by clicking the present set point. (Below click '10 sec').

Output A/output B

Select which relay to activate at an alarm if this is necessary and available.

Password level

Select which password level that is needed to modify this parameter.

Enable

To activate the alarm function, select ON or RUN in the list. (If RUN is selected, the alarm function will be activated when the gen-set is running).

High alarm

Mark this check box to get an alarm when the input is activated. Unmark this check box to get an alarm when the input is deactivated.

## 4. Parameter list

---

The structure for the binary inputs are identical. The settings are:

Parameter no.	Input term.
3370	127
3380	128
3390	129
3400	130
3410	131
3420	132
3430	133

The setting structure is:

No.	Setting		Min. setting	Max. setting	Factory setting
3372	Bin. in term. 127	Timer	0.0 s	100.0 s	10.0 s
3373	Bin. in term. 127	Relay output A	R0 (none)	Option dependent	R0 (none)
3374	Bin. in term. 127	Relay output B	R0 (none)		R0 (none)
3375	Bin. in term. 127	Enable	OFF	ON	OFF



The parameter 3370 is used as an example. The structure is the same for the other parameters.

DEIF A/S reserves the right to change any of the above