

Description of options

Option F1 and F2, Analogue transducer outputs Multi-line 2 – version 2

4189340272D

SW version 2.4X.X

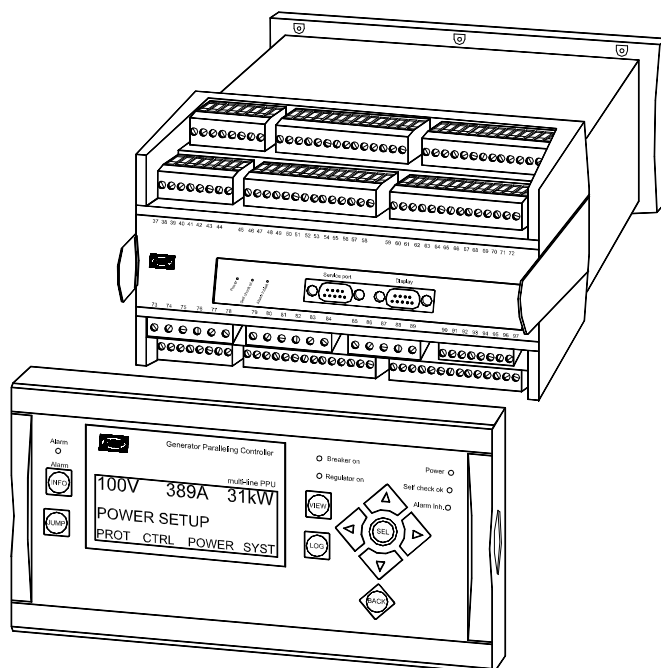

- *Description of option*
- *Functional description*
- *Parameter list*

CE

Table of contents

1. WARNINGS AND LEGAL INFORMATION	3
LEGAL INFORMATION AND RESPONSIBILITY.....	3
ELECTROSTATIC DISCHARGE AWARENESS	3
SAFETY ISSUES.....	3
DEFINITIONS	3
2. DESCRIPTION OF OPTION	4
F1 AND F2 OPTIONS	4
TERMINAL DESCRIPTION.....	4
3. FUNCTIONAL DESCRIPTION	5
WIRING EXAMPLE	5
CONFIGURATION OF TRANSDUCER OUTPUTS	5
4. PARAMETER LIST	8
OUTPUT SETTINGS, OPTIONS F1 AND F2	8

This manual is valid for standard Multi-line 2 PPU/GPU/GPC units with firmware version 2.00.0 or later.

1. Warnings and legal information

Legal information and responsibility

DEIF takes no responsibility for installation or operation of the generator set. If there is any doubt about how to install or operate the generator set controlled by the unit, the company responsible for the installation or the operation of the set must be contacted.

The units are not to be opened by unauthorised personnel. If opened anyway, the warranty will be lost.

Electrostatic discharge awareness

Sufficient care must be taken to protect the terminals against static discharges during the installation. Once the unit is installed and connected, these precautions are no longer necessary.

Safety issues

Installing the unit implies work with dangerous currents and voltages. Therefore, the installation should only be carried out by authorised personnel who understand the risks involved in working with live electrical equipment.



Be aware of the hazardous live currents and voltages. Do not touch any AC measurement inputs as this could lead to injury or death.

Definitions

Throughout this document a number of notes and warnings will be presented. To ensure that these are noticed, they will be highlighted in order to separate them from the general text.

Notes



The notes provide general information which will be helpful for the reader to bear in mind.

Warning



The warnings indicate a potentially dangerous situation which could result in death, personal injury or damaged equipment, if certain guidelines are not followed.

2. Description of option

F1 and F2 options

The options F1 and F2 are hardware options, and therefore separate PCBs are installed in addition to the standard-installed hardware.

Option F1/F2 covers the following ANSI code:

Function	ANSI no.
Option F1: 2 x 0(4)...20mA outputs	77
Option F2: 4 x 0(4)...20mA outputs	77

Terminal description

The outputs are active outputs. This means that they use the controller unit's power supply, and therefore no external supply can be connected.



Option F1 is available for the GPU, GPC and the PPU.
Option F2 is available for the GPU and only if option G2 is not selected.

Option F1

Term.	Function	Description
90	Not used	
91	0	Analogue output 1, selectable
92	0(4) - 20mA out	
93	Not used	
94	Not used	
95	0	Analogue output 2, selectable
96	0(4) - 20mA out	
97	Not used	

Option F2

Term.	Function	Description
65	Not used	
66	0(4) - 20 mA out	Analogue output 4, selectable
67	0	
68	Not used	
69	Not used	
70	0(4) - 20 mA out	Analogue output 3, selectable
71	0	
72	Not used	



Option F2 includes both F1 and F2 outputs (4 outputs total).

3. Functional description

The transducer outputs are active and galvanically separated.

Wiring example

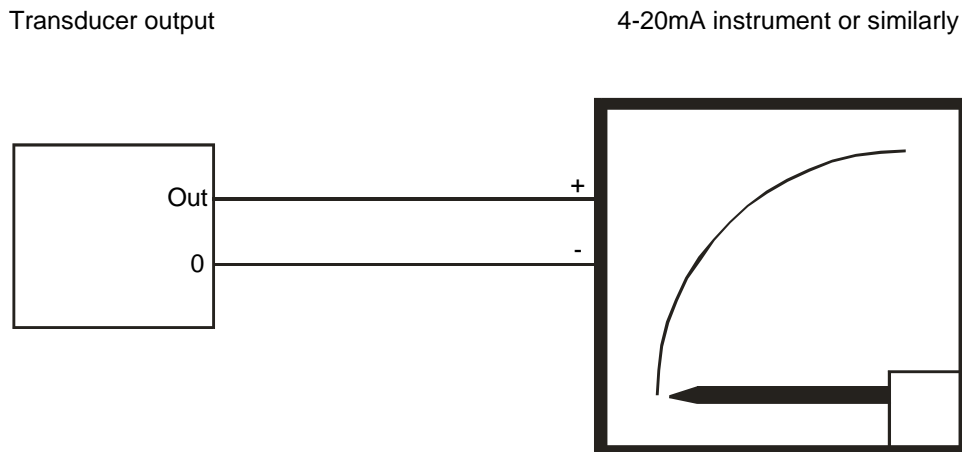

The outputs from the controller unit are active outputs, and no external supply can be connected.

Configuration of transducer outputs

Configuration of the transducer outputs can be done from the PC utility software or from the display.

Configuration from the utility software

When the configuration of the transducer outputs is made from the PC utility software, the configuration is done in four steps.

In this example, the transducer output must relate to the power measurement (kW).

Step 1:

Upload the parameters from the Multi-line 2.

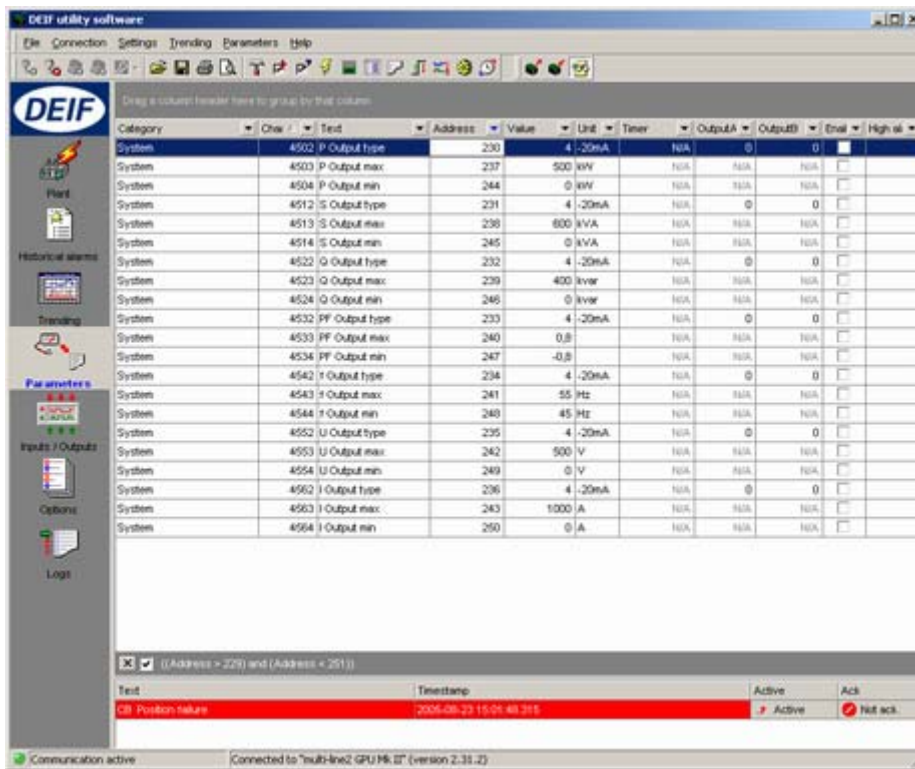

Step 2:

Locate menu 4502 in the list below and double click the marked line. A dialogue box appears and the transducer output can be selected. Write the value to the Multi-line 2.

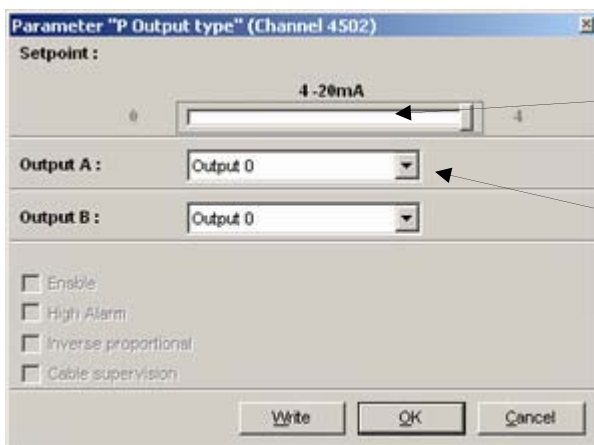

Select output type 0-20mA or 4-20mA.

Select output #1 to #4 to activate the transducer output.



The transducer outputs are called output #1 and #2 in option F1.
The transducer outputs are called output #1, #2, #3 and #4 in option F2.

Step 3:

Locate menu 4503 in the parameter list and double click the line. Now, adjust the value that corresponds to 20mA and write the value to the Multi-line 2.

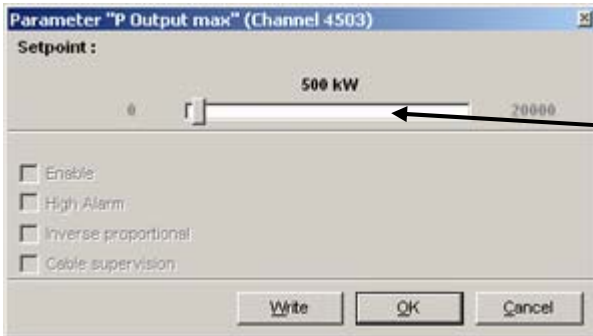

Adjust the value in kW that represents 20mA.

Step 4:

Locate menu 4504 in the parameter list and double click the line. Now, adjust the value that corresponds to 4mA and write the value to the Multi-line 2.

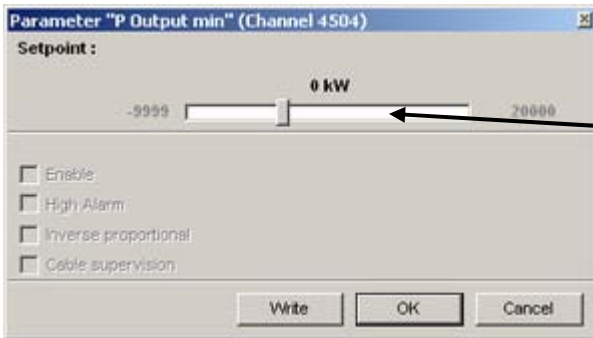

Adjust the value in kW that represents 4mA.

4. Parameter list

The setup of parameters is done via the display or the PC utility software (USW). In the following, the settings are presented in tables.



For further information about the structure of the parameter descriptions, see the Designer's Reference Handbook.

Output settings, options F1 and F2

The analogue output options each consist of two independent 0(4)...20mA outputs. Option F1 has two outputs, and option F2 has four outputs. Each of the two (four) outputs can be chosen to represent any of the following values.

4500 Power output (P kW)

No.	Setting		Min. setting	Max. setting (option F1)	Max. setting (option F2)	Factory setting
4501	Power output	Output A	0	2	4	0
4502	Power output	Output B	0	2	4	0
4503	Power output	Type	0-20mA	4-20mA		4-20mA
4504	Power output	Max. value	0 kW	99 MW		500 kW
4505	Power output	Min. value	-99 MW	99 MW		0 kW

4510 Apparent power output (S kVA)

No.	Setting		Min. setting	Max. setting (option F1)	Max. setting (option F2)	Factory setting
4511	S output	Output A	0	2	4	0
4512	S output	Output B	0	2	4	0
4513	S output	Type	0-20 mA	4-20mA		4-20mA
4514	S output	Max. value	0 kVA	99 MVA		600 kVA
4515	S output	Min. value	-99 MVA	99 MVA		0 kVA

4520 Reactive power output (Q kVAr)

No.	Setting		Min. setting	Max. setting (option F1)	Max. setting (option F2)	Factory setting
4521	Q output	Output A	0	2	4	0
4522	Q output	Output B	0	2	4	0
4523	Q output	Type	0-20mA	4-20mA		4-20mA
4524	Q output	Max. value	0 kVAr	99 MVAr		400 kVAr
4525	Q output	Min. value	-99 MVAr	99 MVAr		0 kVAr

4530 Power factor output (PF)

No.	Setting		Min. setting	Max. setting (option F1)	Max. setting (option F2)	Factory setting
4531	PF output	Output A	0	2	4	0
4532	PF output	Output B	0	2	4	0
4533	PF output	Type	0-20mA	4-20mA		4-20mA
4534	PF output	Max. value	0.5	1		0.8
4535	PF output	Min. value	-0.5	1		-0.8

4540 Generator frequency output (f_{GEN})

No.	Setting		Min. setting	Max. setting (option F1)	Max. setting (option F2)	Factory setting
4541	Freq. output	Output A	0	2	4	0
4542	Freq. output	Output B	0	2	4	0
4543	Freq. output	Type	0-20mA	4-20mA		4-20mA
4544	Freq. output	Max. value	0 Hz	70 Hz		55 Hz
4545	Freq. output	Min. value	0 Hz	70 Hz		45 Hz

4550 Generator voltage output (U_{GEN})

No.	Setting		Min. setting	Max. setting (option F1)	Max. setting (option F2)	Factory setting
4551	Voltage outp.	Output A	0	2	4	0
4552	Voltage outp.	Output B	0	2	4	0
4553	Voltage outp.	Type	0-20mA	4-20mA		4-20mA
4554	Voltage outp.	Max. value	0 V	28000 V		500 V
4555	Voltage outp.	Min. value	0 V	28000 V		0 V



The voltage output represents the L1-L2 voltage.

4560 Generator Current output (I_{GEN})

No.	Setting		Min. setting	Max. setting (option F1)	Max. setting (option F2)	Factory setting
4561	Current outp.	Output A	0	2	4	0
4562	Current outp.	Output B	0	2	4	0
4563	Current outp.	Type	0-20mA	4-20mA		4-20mA
4564	Current outp.	Max. value	0 A	9000 A		1000 A
4565	Current outp.	Min. value	0 A	9000 A		0 A



The current output represents the L1 current.

DEIF A/S reserves the right to change any of the above.